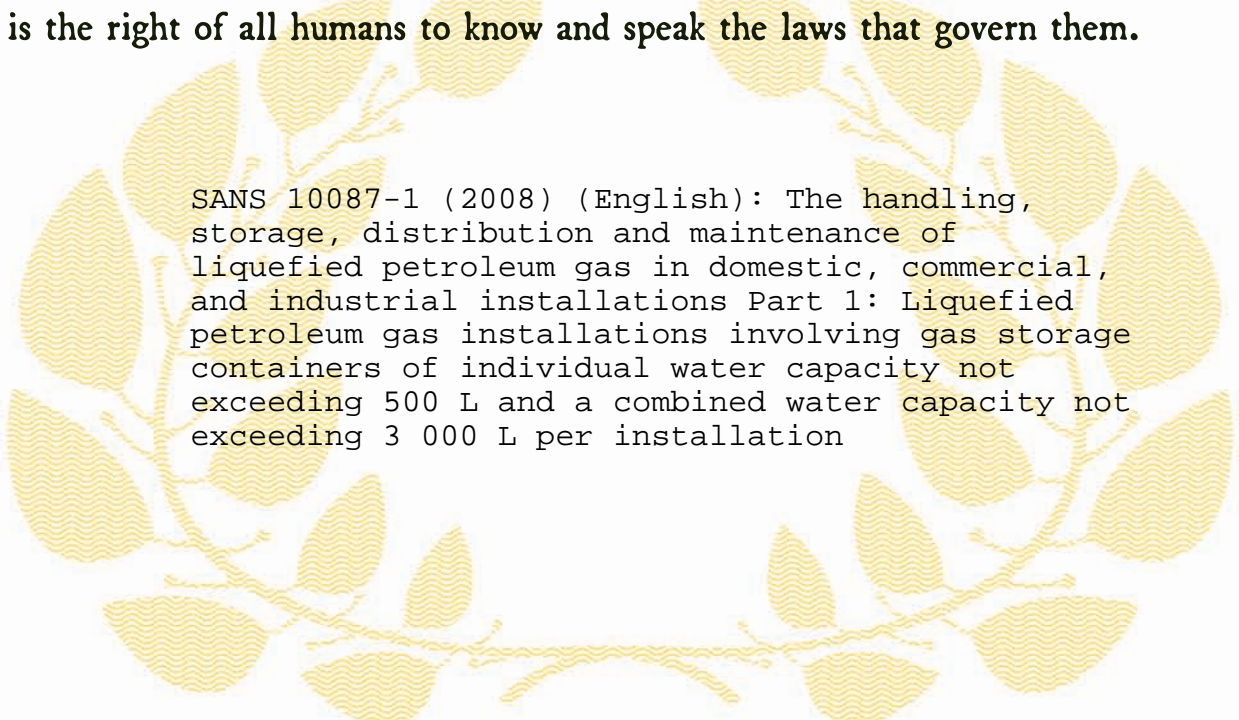




# *Republic of South Africa*

## ✎ EDICT OF GOVERNMENT ✎

In order to promote public education and public safety, equal justice for all, a better informed citizenry, the rule of law, world trade and world peace, this legal document is hereby made available on a noncommercial basis, as it is the right of all humans to know and speak the laws that govern them.



SANS 10087-1 (2008) (English): The handling, storage, distribution and maintenance of liquefied petroleum gas in domestic, commercial, and industrial installations Part 1: Liquefied petroleum gas installations involving gas storage containers of individual water capacity not exceeding 500 L and a combined water capacity not exceeding 3 000 L per installation



BLANK PAGE



## **SOUTH AFRICAN NATIONAL STANDARD**

**The handling, storage, distribution  
and maintenance of liquefied petroleum  
gas in domestic, commercial, and  
industrial installations**

**Part 1: Liquefied petroleum gas installations  
involving gas storage containers of  
individual water capacity not exceeding  
500 L and a combined water capacity  
not exceeding 3 000 L per installation**

**SANS 10087-1:2008**  
Edition 5

**Table of changes**

<b>Change No.</b>	<b>Date</b>	<b>Scope</b>

**Foreword**

This South African standard was approved by National Committee StanSA SC 5120.19A, *Gas supply, handling and control (fuel and industrial gases) – Fuel gases*, in accordance with procedures of Standards South Africa, in compliance with annex 3 of the WTO/TBT agreement.

This document was published in April 2008. This document supersedes SANS 10087-1:2004 (edition 4).

SANS 10087 consists of the following parts, under the general title *The handling, storage, distribution and maintenance of liquefied petroleum gas in domestic, commercial, and industrial installations*:

*Part 1: Liquefied petroleum gas installations involving gas storage containers of individual water capacity not exceeding 500 L and a combined water capacity not exceeding 3 000 L per installation.*

*Part 2: Installations in mobile units and small non-permanent buildings.*

*Part 3: Liquefied petroleum gas installations involving storage vessels of individual water capacity exceeding 500 L.*

*Part 4: Transportation of LPG in bulk by road.*

*Part 6: The application of liquefied petroleum and compressed natural gases as engine fuels for internal combustion engines.*

*Part 7: Storage and filling premises for refillable liquefied petroleum gas (LPG) containers of gas capacity not exceeding 9 kg and the storage of individual gas containers not exceeding 48 kg.*

*Part 8: The fuelling of fork lift trucks and other LP gas operated vehicles.*

*Part 10: Mobile filling stations for refillable liquefied petroleum gas (LPG) containers of capacity not exceeding 9 kg.*

This document was written in order to support a specific South African Regulation and, of necessity, includes references to South African legislation. It therefore might not be suitable for direct application in other jurisdictions where conflicting legislation exists.

Annexes B, E and I form an integral part of this document. Annexes A, C, D, F, G, H, J and K are for information only.

## Contents

	Page
Foreword	
<b>1</b> Scope .....	3
<b>2</b> Normative references .....	3
<b>3</b> Definitions .....	5
<b>4</b> Properties of LPG and precautions to be observed.....	8
<b>5</b> Containers .....	8
<b>6</b> Appliances .....	15
<b>7</b> Piping, fittings and other components .....	17
<b>8</b> Inspection, testing and instructions to users .....	27
<b>9</b> Electrical equipment and other sources of ignition .....	29
<b>10</b> Ongoing inspection and repair .....	30
Figures 1 to 16 .....	31-42
<b>Annex A</b> (informative) Relationship between volume and mass of LPG .....	43
<b>Annex B</b> (normative) In-situ container (dumplies) filling requirements .....	44
<b>Annex C</b> (informative) Determination of adequacy of gas supply .....	45
<b>Annex D</b> (informative) Occupancy classification in accordance with SANS 10400 .....	46
<b>Annex E</b> (normative) Ventilation requirements .....	48
<b>Annex F</b> (informative) Testing the adjustment of burners .....	50
<b>Annex G</b> (informative) Testing the system performance of low-pressure regulators .....	50
<b>Annex H</b> (informative) Determination of pipe sizes in the low-pressure stage .....	51
<b>Annex I</b> (normative) Gas container manifolds and supply systems .....	55
<b>Annex J</b> (informative) Testing of the high-pressure stage of an installation .....	63
<b>Annex K</b> (informative) Testing of the low-pressure stage (as a whole) of an installation by U-gauge .....	64
<b>Bibliography</b> .....	66

**SANS 10087-1:2008**

Edition 5

**This page is intentionally left blank**

## **The handling, storage, distribution and maintenance of liquefied petroleum gas in domestic, commercial, and industrial installations**

### **Part 1:**

Liquefied petroleum gas installations involving gas storage containers of individual water capacity not exceeding 500 L and a combined water capacity not exceeding 3 000 L per installation

## **1 Scope**

**1.1** This part of SANS 10087 specifies requirements for the materials, the methods of construction and the installation of equipment used in liquefied petroleum gas applications for domestic and commercial installations that involve gas storage containers of individual water capacity not exceeding 500 L and of a combined water capacity not exceeding 3 000 L.

NOTE For the storage of containers for retail and exchange purposes, see SANS 10087-7.

**1.2** It also specifies the maintenance, inspection and testing of the various components of the equipment.

**1.3** It covers the installation of appliances, piping, fittings and other components.

NOTE For industrial installations, see SANS 10087-3.

**1.4** It also covers installations in mobile applications (e.g. caravans, mobile homes and shipping containers).

NOTE 1 Installations for caravans apply to storage containers of individual water capacity not exceeding 45 L.

NOTE 2 Installations for mobile homes apply to storage containers of individual water capacity not exceeding 113 L.

## **2 Normative references**

The following referenced documents are indispensable for the application of this document. For dated references, only the edition cited applies. For undated references, the latest edition of the referenced document (including any amendments) applies. Information on currently valid national and international standards can be obtained from Standards South Africa.

API Spec 5L, *Specification for line pipe*.

## **SANS 10087-1:2008**

Edition 5

AS 4176, *Polyethylene/aluminium and cross-linked polyethylene/aluminium macro-composite pipe systems for pressure applications.*

ASME-BPVC 7, *Recommended guidelines for the care of power boilers.*

ASTM B 813, *Standard specification for liquid and paste fluxes for soldering of copper and copper alloy tube.*

ASTM F 1281, *Standard specification for crosslinked polyethylene/aluminum/crosslinked polyethylene (PEX-AL-PEX) pressure pipe.*

ASTM F 1282, *Standard specification for polyethylene/aluminum/polyethylene (PE-AL-PE) composite pressure pipe.*

BS 1600, *Specification for dimensions of steel pipe for the petroleum industry.*

BS 3212, *Specification for flexible rubber tubing, rubber hose and rubber hose assemblies for use in LPG vapour phase and LPG/air installations.*

BS 5292, *Specification for jointing materials and compounds for installations using water, low-pressure steam or 1st, 2nd and 3rd family gases.*

EN 1762, *Rubber hoses and hose assemblies for liquefied petroleum gas, LPG (liquid or gaseous phase), and natural gas up to 25 bar (2,5 MPa) – Specification.*

EN 15266, *Stainless steel pliable corrugated tubing kits in buildings for gas with an operating pressure up to 0,5 bar.*

ISO 17484-1, *Plastics piping systems – Multilayer pipe systems for indoor gas installations with a maximum operating pressure up to and including 5 bar (500 kPa) – Part 1: Specifications for systems.*

SANS 24 (SABS 24), *Soft solders.*

SANS 62-1, *Steel pipes – Part 1: Pipes suitable for threading and of nominal size not exceeding 150 mm.*

SANS 199, *Shut-off valves for refillable liquefied petroleum gas cylinders.*

SANS 252, *Metallic hose assemblies for liquid petroleum gases and liquefied natural gases.*

SANS 460, *Plain-ended solid drawn copper tubes for potable water.*

SANS 974-1 (SABS 974-1), *Rubber joint rings (non-cellular) – Part 1: Joint rings for use in water, sewer and drainage systems.*

SANS 1067-2, *Copper-based fittings for copper tubes – Part 2: Capillary solder fittings.*

SANS 1091, *National colour standard.*

SANS 1123, *Pipe flanges.*

SANS 1156-2, *Hose for liquefied petroleum gas (LPG) – Part 2: Hose and tubing for use in LPG vapour phase and LPG-air installations.*

SANS 1186-1, *Symbolic safety signs – Part 1: Standard signs and general requirements.*



SANS 1237, *Single-stage regulators for liquefied petroleum gas (LPG).*

SANS 1539, *Appliances operating on liquefied petroleum gas – Safety aspects.*

SANS 1830, *Flexible piping for underground use at service stations and consumer installations.*

SANS 1910, *Portable refillable fire extinguishers.*

SANS 10019, *Transportable containers for compressed, dissolved and liquefied gases – Basic design, manufacture, use and maintenance.*

SANS 10087-3, *The handling, storage, distribution and maintenance of liquefied petroleum gas in domestic, commercial, and industrial installations – Part 3: Liquefied petroleum gas installations involving storage vessels of individual water capacity exceeding 500 L.*

SANS 10087-7, *The handling, storage, distribution and maintenance of liquefied petroleum gas in domestic, commercial, and industrial installations – Part 7: Storage and filling premises for refillable liquefied petroleum gas (LPG) containers of gas capacity not exceeding 9 kg and the storage of individual gas containers not exceeding 48 kg.*

SANS 10140-3, *Identification colour markings – Part 3: Contents of pipelines.*

SANS 10268-2, *Welding of thermoplastics – Welding processes – Part 2: Electrofusion welding.*

SANS 10400 (SABS 0400), *The application of the National Building Regulations.*

### **3 Definitions**

For the purposes of this document, the following definitions apply.

#### **3.1**

##### **acceptable**

acceptable to the approving authority

#### **3.2**

##### **approved**

approved by the approving authority

#### **3.3**

##### **approving authority**

appropriate of the following:

- a) within the scope of the Trade Metrology Act, 1973 (Act No. 77 of 1973), and in respect of the control of the mass of gas sold: the Director of Trade Metrology;
- b) within the scope of the Occupational Health and Safety Act, 1993 (Act No. 85 of 1993), and in respect of the control of general safety: the Chief Inspector;
- c) within the scope of SANS 10400 and in respect of the evaluation and control of installations in accordance with this part of SANS 10087: the local authority in whose area of jurisdiction the installation is installed;
- d) within the scope of the Mine Health and Safety Act, 1996 (Act No. 29 of 1996), and in respect of the control of general safety: the Chief Inspector

## **SANS 10087-1:2008**

Edition 5

### **3.4**

#### **assembly**

system that includes connection by pipe or similar ducts, fittings and valves that operate under gauge pressure and are used for the conveyance of liquid or vapour

### **3.5**

#### **caravan**

motor home

small dwelling that is used for domestic or recreational purposes and that can be towed by a vehicle or is self-propelled

### **3.6**

#### **competent person**

any person that has the knowledge, training and experience specific to the work or task being performed

### **3.7**

#### **container**

cylinder that complies with SANS 10019 and that is approved for the storage and conveyance of liquefied petroleum gas of individual water capacity not exceeding 500 L

### **3.8**

#### **critical location**

area that is not ventilated for the dispersal of LPG

### **3.9**

#### **equipment**

combination of pipes, pipe fittings, appliances and any appurtenances connected to the system

### **3.10**

#### **fixed appliance**

any appliance that is permanently mounted into a fixture, for example, a stove or a fireplace

### **3.11**

#### **installation**

combination of one or more containers connected to a manifold system, including pipework and appliances

### **3.12**

#### **liquefied petroleum gas**

#### **LPG**

commercial butane, commercial propane, or a mixture of light hydrocarbons (predominantly propane, propene, butane and butene) that is gaseous under conditions of ambient temperatures and pressure, and that is liquefied by an increase of pressure or a lowering of temperature

### **3.13**

#### **manifold**

where two or more containers are connected to each side of the changeover device

### **3.14**

#### **mechanical joint**

any joint that is made by the application of a mechanically or manually applied force that uses threads to tighten couplings, or crimping, or sealing rings, or washers, or any other sealing medium

NOTE Welded, soldered or, in the case of HDPE piping, electrofused jointing are excluded and not deemed to be mechanical joints.

**3.15**

**mobile home**

dwelling that is larger than a caravan mobile unit and that can be towed by a motor vehicle

**3.16**

**mobile unit**

purpose-built unit, vehicle, or caravan which may accommodate appliances for gas use

**3.17**

**operating pressure**

pressure at which an appliance will operate (gauge pressure)

**3.17.1**

**high pressure**

pressure that exceeds 150 kPa (gauge pressure)

**3.17.2**

**intermediate pressure**

pressure that exceeds 5 kPa but that does not exceed 150 kPa

**3.17.3**

**low pressure**

pressure that does not exceed 5 kPa

**3.18**

**pressure regulator**

device that reduces the pressure of the gas from a higher pressure to a constant lower pressure

**3.19**

**registered installer**

person that has the ability, appropriate training, knowledge and experience to carry out the work that is undertaken in a safe and proper manner, and who is registered in accordance with the requirements of the Occupational Health and Safety Act, 1993 (Act No. 85 of 1993)

**3.20**

**user**

person who uses the equipment for his own benefit, or has the right of control over the use of the equipment, but does not include a lessor or any person employed in connection with that equipment

**3.21**

**ventilation**

supply and removal of air (by natural or mechanical means (or both)) to and from a space or spaces in a building

NOTE It normally comprises a combination of purpose-provided ventilation and infiltration.

**3.21.1**

**permanent ventilation**

ventilation opening which is permanently fixed in the open position

**3.21.2**

**ventilation opening**

any means of purpose-provided ventilation (whether it is permanent or closable), which opens directly to external air, such as the openable parts of a window, a louvre or a background ventilator

NOTE It also includes any door that opens directly to external air.

## **4 Properties of LPG and precautions to be observed**

The location of LPG containers shall be planned and put into effect with full regard for the properties of the gas and the construction of installations for conveying this gas in domestic dwellings and commercial buildings. All persons concerned with the installation of containers and appliances shall be registered installers in this respect and shall be familiar with the following characteristics of the gas and the precautions to be observed:

- a) The gas is stored as liquid under pressure.
- b) Leakage, especially of liquid, will release large volumes of highly flammable gas.
- c) A gas-air mixture that contains approximately 1,5 % to 10 % of LPG is flammable. If a large enough volume of gas is so dispersed in the atmosphere as to reach flammable proportions throughout, ignition of the mixture will result in a rate of combustion of near-explosive force.

NOTE For further information regarding the relationship between volume and mass of LPG, see annex A.

- d) LPG is denser than air and will flow along the ground or through drains. It can be ignited at a considerable distance from the source of leakage, therefore low-level ventilation of buildings shall be provided.
- e) LPG is non-toxic, but since it can induce headaches and dizziness when inhaled, inhalation of LPG should be avoided whenever possible.
- f) LPG liquid, by its rapid vaporization and consequent lowering of the temperature, can cause severe cold burns when it comes into contact with the skin. Appropriate protective clothing, such as gloves, goggles, aprons, and gumboots, shall be worn when there is any possibility of such contact. Because of the hazard of the generation of static electricity, the soles of gumboots shall be made of leather or conductive rubber, and clothing shall not be made of fabrics that contain artificial fibres.
- g) A container that has held LPG and is presumed to be "empty" can still be hazardous. In this state, the internal pressure is approximately atmospheric and, if the valve leaks or is left open, air can diffuse into the container and form a flammable or explosive mixture. Furthermore, even an "empty" container that does not yield gas when the valve is opened, might in fact not be quite empty. In cold weather, the heavier fractions of the liquid might not vaporize and will therefore remain in the container. All containers that are (or appear to be) empty shall be handled with the same care as a full container, and valves shall be kept fully closed at all times when containers are not in use.
- h) There are hazards involved with the filling of containers (see annex B).

## **5 Containers**

### **5.1 Number and size of containers**

#### **5.1.1 General**

The number and the size of containers recommended for an LPG installation depend on the maximum hourly consumption of the appliances served and the lowest ambient temperature expected. When an installation is designed, care shall be taken to guard against possible failure of the gas supply due to vaporization problems.

If a supply has to be maintained over a long period, the discharge of gas diminishes slowly until it reaches a state of equilibrium with the vaporization rate of the LPG in the container. This vaporization rate, in turn, depends on the size of the container, the amount of LPG that remains in the container, and the ambient temperature (see annex C).

One supply container (48 kg) and one reserve container of the same size are normally enough for ordinary installations in permanent dwellings. However, there are larger installations that require more gas, and the maximum gas off-take for these installations and the number of containers required can be calculated in accordance with 5.1.2.

NOTE A maximum combined capacity of 38 kg is allowed for installations on mobile units.

**5.1.2 Calculation of container details**

**5.1.2.1** Table 1 gives the approximate vaporization rates of the larger containers currently available.

**5.1.2.2** Table 2 gives, in terms of three of the more popular domestic-type container sizes, the approximate container requirements of some typical appliances, based on their gas consumption per hour and the vaporization rates for the containers. Use of this approach facilitates calculation of the containers required for a specific installation.

**5.1.2.3** The total requirements of an installation are obtained from the sum of the requirements of the individual appliances comprising the installation. For an installation consisting of a normal-sized stove, an instantaneous single-point water heater, a refrigerator, and eight gaslights, the container requirements shall be as given in table 3.

Two 45 L (19 kg) containers coupled in parallel, or one 113 L (48 kg) container would, therefore, be acceptable. The best arrangement, however, would be one 113 L (48 kg) container, with a second one in reserve.

**Table 1 — Vaporization rates for containers**

1		2		3		4	
Nominal size of container				Approximate vaporization rates			
Water capacity		Nominal mass of gas					
L		kg		L/h		g/h	
22		9		100		230	
34		13 to 14		140		320	
45		19		200		460	
113		48		400		920	
454		196		1 000		2 300	

NOTE For the convenience of users of this part of SANS 10087, the LPG mass capacity equivalents for the various container sizes are also given in tables 1 and 2. It should, however, be stressed that these are only nominal equivalents and that the exact mass equivalents will depend on the actual density of the product filled into the containers.

**Table 2 — Container requirements of typical appliances**

1	2	3	4	5
Appliance	Approximate number of containers required			Approximate input kJ/h
	Capacity of container			
	22 L (9 kg)	45 L (19 kg) <sup>a</sup>	113 L (48 kg)	
Gas stove, normal domestic	1,50	0,65	0,32	42 000
Gas stove, large domestic	2,25	1,00	0,50	63 000
Hotplate (2 burner)	1,00	0,25	0,12	16 000
Instantaneous water heater, multipoint	4,60	2,00	1,00	74 000
Instantaneous water heater, single point	2,00	0,84	0,42	37 000
Gaslight	0,10	0,04	0,02	2 000
Gas iron	0,20	0,08	0,04	3 000
Refrigerator	0,10	0,04	0,02	2 000
Space heater, large, with flue	2,00	0,84	0,42	37 000
Space heater, small, portable type	0,40	0,16	0,08	5 000
NOTE 1 The container requirements may be scaled down if it is unlikely that all appliances will be used simultaneously for long periods of time.				
NOTE 2 This table is based on results that are typical for cold-winter conditions in South Africa; in warmer conditions the requirements will be less. With experience, a registered installer will learn how the values can be modified to suit local conditions.				
<sup>a</sup> It has been found in practice that the approximations given for 45 L (19 kg) containers can usually also be used for 34 L (13/14 kg) containers.				

**Table 3 — Container requirements for an installation**

1	2	3	4
Appliance	Number of containers required		
	22 L (9 kg)	45 L (19 kg)	113 L (48 kg)
Gas stove, normal domestic	1,50	0,65	0,32
Instantaneous water heater, single point	2,00	0,84	0,42
Refrigerator	0,10	0,04	0,02
Gaslights (8 × value given in table 2)	0,80	0,32	0,16
Total number of containers	4,40	1,85	0,92

## **5.2 Location of containers**

### **5.2.1 General**

**5.2.1.1** The installation of a container(s), complete with all associated equipment and appliances and any subsequent repair or modifications to the installation, shall be carried out by a registered installer qualified to the appropriate grade (domestic or commercial grade).

The storage of containers shall be in accordance with SANS 10087-3 or SANS 10087-7.

NOTE This requirement does not include the replacement of containers.

**5.2.1.2** Each container shall be located in an upright position with the valve uppermost, and shall be so placed on a firm level base that there can be no danger of the container tilting or falling over.

**5.2.1.3** Containers shall be so located in an accessible position that

- a) full and empty containers can be changed easily,
- b) they can be disconnected and removed quickly in case of an emergency, and
- c) the container valve can be easily operated.

**5.2.1.4** In the selection of a location for containers, the following locations shall be avoided:

- a) any position in which the containers are likely to cause obstruction, to become damaged or to be exposed to conditions likely to affect their safety;
- b) any position that is subject to extremes of temperature (excluding natural elements);
- c) any position near corrosive or readily combustible substances; and
- d) any position adjacent to cellars, drains, hollows, etc., where escaping gas might collect.

### **5.2.2 Indoor location**

**5.2.2.1** Where LPG containers are permanently installed or stored in a building, the type of building (as defined in the relevant part of SANS 10400, see also annex D) and the corresponding size of the container(s) shall be as follows:

- a) flats (H3): a maximum of 9 kg per flat;
- b) houses (including cluster housing and group housing (not exceeding two storeys)): a total maximum of 19 kg;
- c) commercial premises (all occupancies not mentioned in this part of SANS 10087): a total maximum of 19 kg per unit, provided that there is a separating element that complies with the requirements of SANS 10400;
- d) industrial premises (D1 to D4): a maximum of 19 kg per 600 m<sup>3</sup> of building space with a total maximum of 100 kg; and
- e) for special events: consult the local fire authority concerned.

**5.2.2.2** Containers shall never be located below ground level in a building, for example, in cellars or basements.

## **SANS 10087-1:2008**

Edition 5

**5.2.2.3** Containers shall not be located above or on top of any appliance used for cooking or heating.

**5.2.2.4** Containers shall be located in a place with floor-level ventilation to the outside air to prevent any possible accumulation of gas in the event of leakage. Where this is not possible, the requirements of annex E shall be applied. An airbrick situated near the bottom of an external wall or a normal gap of at least 6 mm underneath an external door (or a combination of these) usually provides sufficient ventilation (see figure 1 and annex E).

**5.2.2.5** Containers shall be located at least 300 mm away from a gas stove (see figure 1) unless the container is protected from the heat of the stove in an approved manner.

**5.2.2.6** Containers shall be located at least 2 m away from any coal stove, except that this distance can be reduced to 1 m if a non-combustible insulating guard is fitted between the container and the stove (see figure 2).

**5.2.2.7** Containers inside a building shall not be manifolded.

**5.2.2.8** The dimensions shown in figures 1 and 2 shall be the minimum requirements for container positions.

### **5.2.3 Outdoor location** (see figures 3, 4 and 5)

**5.2.3.1** Containers shall be located on a firm, clean, well-drained and level base. The area surrounding a container shall be kept clear of combustible materials, for example, weeds, dry grass, paper and waste. Containers shall be located and protected against tampering by unauthorized persons and also damage and interference by, for example, animals and vehicles.

**5.2.3.2** Containers shall be at least

- a) 1 m away from any opening (into a building) that is below the level of the container valve, i.e. doors, windows and airbricks,
- b) 2 m away from any drain, pit or manhole,
- c) 3 m away from the property boundary, unless the boundary has a firewall, in which case the containers could be next to the firewall (see figures 3 and 4), and where there are only two containers, the boundary distance can be reduced to 1 m, and
- d) 3 m away from any opening (or window) directly above the containers, unless a non-combustible roof (see SANS 10400) is installed between the containers and the opening (or window) (see also figures 3 and 4). However, containers may be placed within the 3 m safety distance provided that the requirements given in 5.2.3.7 are complied with.

**5.2.3.3** All installations shall be fitted with signage indicating no smoking, no naked lights, no unauthorized entry and no cellular phones allowed, i.e. the appropriate pictograms PV 1, PV 2, PV 3 and PV 27 as given in SANS 1186-1.

**5.2.3.4** Where cylinder installations are located adjacent to or directly under the roof covering of a building that is of thatched construction or other combustible material, the local authority concerned shall be consulted in terms of the location and placement of the gas containers.

**5.2.3.5** In the case of single cylinder connections, where the LPG regulator is fitted into the cylinder valve, a flexible hose shall be attached to the regulator outlet. The free end of the hose shall be fitted onto a hose nozzle (see figures 6 and 7) which itself shall be affixed to a wall adjacent to the cylinder by means of a holder bat (see figure 8).



Where the regulator is affixed to the wall by means of a bracket (see figures 9 and 10), the gas supply between the cylinder and the regulator shall be by means of an LPG pigtail with a bull nose fitting at one end, and a threaded connection at the other end to fit the regulator inlet.

**5.2.3.6** In the case of multi-cylinder connections, where cylinders are connected by means of a changeover valve, the regulator and changeover switch shall be wall mounted (see figure 11), with the gas supply from each cylinder being by means of individual pigtails as shown in figure 11.

**5.2.3.7** Glazing may be allowed where the window frames are constructed from metal and the total size of the glazing does not exceed 1 m<sup>2</sup>. Glazing shall be of wire woven glass not larger than 450 mm × 450 mm per pane. Such windows shall not be openable.

**5.2.3.8** Where more than two containers are used in an installation, the containers shall be connected into a manifold system. A changeover device connected to one container on each side shall not be deemed to be a manifold, however, the safety distances shall still apply.

**5.2.3.9** The containers shall be connected to the manifold system by one of the following methods:

- a) on a single branch, up to ten containers of size up to and including 113 L (48 kg) with a maximum of 20 cylinders per installation; or
- b) on a single branch, up to three containers of size up to and including 500 L (196 kg) with a maximum of 6 containers per installation.

NOTE For filling ratios, see SANS 10087-7.

#### **5.2.4 Containers located on building roofs**

Containers may be installed on the roof of a building of fire-resistive construction, or non-combustible construction and having essentially non-combustible contents, or of other construction or contents that are protected with automatic sprinklers, provided that

- a) the total capacity of containers connected to a manifold is not greater than 480 kg and that if more than one manifolded group is located on the roof, the distance between one manifolded group and any other such group shall be at least 15 m,
- b) the containers are located in areas where there is free air circulation, and that are at least 3 m from building openings (for example, windows and doors), and at least 6 m from air intakes, and air conditioning and ventilation systems,
- c) the containers are not located on a roof that is entirely enclosed by parapets of height more than 0,45 m unless
  - 1) the parapets are breached with low-level ventilation openings that are not more than 6 m apart, or
  - 2) all openings that communicate with the interior of the building are at or above the top of the parapet,
- d) the hose used for connecting to the containers shall be in accordance with the requirements of SANS 252,
- e) the local fire department is advised of each installation by means of the approved plans, and
- f) it can be ensured that
  - 1) containers shall not be refilled on the roof,

## **SANS 10087-1:2008**

Edition 5

- 2) each container valve outlet shall be tightly plugged during movement of the containers within the building, and that the only means of access used shall be emergency stairways not generally used by the public, or freight or passenger lifts not occupied by the public, and
- 3) that all precautions shall be taken to avoid damage to containers when they are being taken to and from the roof, and to prevent them from being allowed to fall down stairways or from the roof.

### **5.2.5 Container location requirements for caravans, self-propelled vehicles and mobile catering equipment**

#### **5.2.5.1 General**

When LPG containers are installed in caravans, the installation shall be on the outside of the caravan. If the installation is inside the caravan, it shall be in a vapour-tight recess or cabinet which shall only be accessible from and vented to the outside.

The vents shall be located near the top and bottom of the enclosure and 1 m horizontally away from any opening into the caravan below the level of the vents.

A sign to inform the user that: "whilst in motion, all gas supply valves shall be closed" shall be affixed in a prominent position in the enclosure.

#### **5.2.5.2 Appliance installations for caravans**

All appliances shall generally be installed into caravans in the same manner as for normal domestic installations.

The type of piping to be used shall be copper or bundie (hydraulic pressure tube) tubing.

#### **5.2.5.3 Towed and self-propelled vehicles**

Containers mounted inside towed and self-propelled vehicles shall

- a) be located in an enclosure that is securely mounted to the vehicle,
- b) be gas-tight with respect to the driver or passenger compartment or any spark-producing equipment,
- c) be vented to the outside, and
- d) have a capacity that does not exceed 19 kg.

#### **5.2.5.4 Mobile catering equipment**

For mobile catering equipment, a rational design shall be required where the gas capacity exceeds 19 kg.

### **5.3 Safety distances**

**5.3.1** The distance between the shell of any one container in an LPG installation and the shell of any one container in another LPG installation shall be at least 6 m. Where there is a firewall between them with a fire rating of at least 2 h and a height of at least 1,8 m, the distance measured from shell to shell around the wall shall be at least 3 m.

**5.3.2** The distance between any LPG container and any other type of flammable or oxidizing compressed gas container shall be at least 3 m.

**5.3.3** Where containers are manifolded, they shall not exceed ten containers per manifold branch. However, dumpies shall not exceed six in total (see figure 5).

**5.3.4** Where the pigtail connections are on a manifold system, the distance between these connections shall not be more than 1 m. Pigtails shall not exceed 1 m in length.

**5.3.5** Other configurations can be motivated. Where other configurations are used, the use of cooling water for fire-fighting purposes and the accessibility of the shut-off valve for closing purposes shall be considered.

## **6 Appliances**

### **6.1 General**

Appliances with a consumption rate that does not exceed 10 kg/h shall comply with the requirements of SANS 1539.

### **6.2 Installation of appliances**

**6.2.1** Fixed appliances shall be installed by a registered installer. When siting an appliance, due regard shall be paid to convenience in use, to protection from draughts and damage, and to the layout of the gas piping system. Pipe runs shall be as neat, tidy and as short as possible. Pressure regulators shall be of an approved type. Low-pressure regulators shall comply with SANS 1237.

**6.2.2** Appliances shall be installed on a firm and level base (this is specially important in the case of refrigerators which require checking with a spirit level during installation). A table or shelf used as a support for an appliance shall be large enough to accommodate the appliance and, unless the support has edges that are flanged upwards, shall provide margins that are wide enough to prevent the appliance from slipping off the support. All appliance supports (including floors, walls and ceilings) shall be strong enough to carry the appliance(s) and all superimposed loads.

**6.2.3** Appliances shall be connected to the pipework of an installation in a way that will eliminate undue strain on the pipework and fittings and, if rigid connections are used, the appliances shall also be so rigidly fixed that they are not capable of being moved after their installation. If an appliance needs to be moved for cleaning etc., it shall be connected to the pipework by means of flexible tubing or hose. To prevent the hose or tubing from being ruptured or torn from its mountings, the appliance shall have a restraining mechanism of a length that is shorter than the hose or tube. Tubing and hoses shall comply with the appropriate requirements given in SANS 1539.

**6.2.4** Appliances shall be installed in such a way as to avoid draughts that are strong enough to extinguish the burners when they are set on "low" flame.

**6.2.5** Appliances shall not be installed in small, confined spaces that are poorly ventilated. Gas burners require an unrestricted supply of fresh air and when a cooking appliance is being built in, the supply of fresh air for combustion shall not be impeded. Provision shall be made for any accumulations of unburnt gas to disperse safely, and also for the free escape of products of combustion. Where gas appliances that require back ventilation are installed against a wall, there shall be a gap of at least 50 mm between the appliance and the wall.

NOTE For the testing of adjustment of burners, see annex F.

**6.2.6** In any bathroom in which a conventional gas water heater (geyser) is installed, the heater shall be flued to the outside and provision shall be made to ensure permanent ventilation (see annex E).

NOTE The manufacturer's operating instructions should be observed (see also 8.2).

## **SANS 10087-1:2008**

Edition 5

**6.2.7** Vent-free space heaters shall not be installed in separately enclosed bathrooms.

**6.2.8** Appliances shall be so sited in a room that there is no danger that they could set fire to furnishings (for example, a gas stove shall not be positioned immediately below a combustible shelf or in a position where curtains could be near its cooking top).

**6.2.9** Where combustible or ignitable material near an appliance is liable to attain ignition temperature or to be exposed to heat damage, provision shall be made to protect such material.

The material can be protected by mounting an insulating non-combustible material between the appliance and the combustible material so as to provide an air space of width at least 15 mm. Where built-in kitchen equipment is used, the surfaces of adjacent structures in contact with an appliance shall be of materials that will not deteriorate at temperatures of up to 150 °C.

**6.2.10** If several appliances are connected to a system, those with the highest rate of gas consumption should be placed nearest to the gas supply point. Alternatively, the supply point should be brought as close as possible to the high-intake appliance(s).

**6.2.11** A water heater should be placed conveniently close to the sink or bath that it serves and, to minimize loss of heat, the run of hot-water piping should be kept as short as possible.

**6.2.12** Hotplates that are open underneath shall not be placed on any combustible surface. Alternatively, a combustible surface shall be protected from the heat of the burners.

**6.2.13** Lighting appliances shall not be installed in positions likely to cause overheating of walls and ceilings, and deflector plates shall be used where necessary.

### **6.3 Provision for ventilation**

**6.3.1** The incorrect installation or use of LPG appliances in buildings can give rise to a variety of hazardous conditions, such as a build-up of unburnt gas, a high concentration of carbon monoxide and the depletion of oxygen. The provision of ventilation is therefore of vital importance and in this regard special notice shall be taken of the warnings and recommendations given in the use and installation brochures supplied with the appliance (see also annex E). Ventilation provisions and requirements can also be found in SANS 1539.

**6.3.2** If the room or space in which a vent-free space heater is to be installed is such that the total heat input rating of the vent-free heater plus any other gas, solid fuel or paraffin appliances in the room, if present, is greater than 0,37 MJ/m<sup>3</sup> of the room volume, then permanent ventilation (see annex E) shall be supplied to the room.

**6.3.3** Where permanent ventilation is required, the minimum cross-sectional area shall be 13 cm<sup>2</sup>/MJ of the total appliance(s) rated heat input.

**6.3.4** In determining the room volume to be used by calculating the allowable heat input to comply with the requirements of 6.3.2, adjoining rooms or spaces may be added to the room volume of the room in which the appliance is to be installed, providing that the access to the adjoining room or space is permanently open.

**6.3.5** Where vent-free heaters are installed in a bedroom, permanent ventilation shall be supplied to the outside atmosphere, regardless of the room size.

## 7 Piping, fittings and other components

### 7.1 Materials

7.1.1 The following pipes and fittings are recommended for general use in installations:

- a) solid drawn copper tube with copper or copper alloy fittings;
- b) ungalvanized seamless mild steel tube with mild steel fittings;
- c) stainless steel piping with associated fittings;
- d) brass fittings that are protected against seasonal cracking;
- e) high density polyethylene (HDPE) pipes and fittings (only to be used for gas in the vapour phase and where the pipes are buried);
- f) flexible tubing and hose; and
- g) composite pressure pipe.

7.1.2 Materials used in the pipe system shall comply with the appropriate of the following standards and should be clearly marked in accordance with the relevant manufacturing standard to prove such compliance:

- a) Copper tubes (class I tubing or better): SANS 460  
(phosphorus deoxidized copper Cu-DHP)
- b) Copper-based fittings: SANS 1067-2
- c) Stainless steel piping and associated fittings: EN 15266

EN 15266 requires the pipe cover to be coloured yellow, however, in South Africa this requirement is light stone. If the pipe is banded it will comply with the national requirements.

- d) Rubber hose (braided) type 1: EN 1762
- e) Flexible rubber tubing or hose: BS 3212 or SANS 1156-2
- f) Jointing materials and compounds: BS 5292
- g) Low-pressure regulators: SANS 1237

NOTE See also annex G for further information regarding the testing of low-pressure regulators.

- h) Steel pipes and wrought steel fittings: SANS 62-1 (medium or heavy duty)

Where pipe in accordance with SANS 62-1 is used, it shall be used in place of a schedule 40 pipe only.

- i) Steel pipes and wrought steel fittings: BS 1600 (seamless only)
- j) HDPE pipes and fittings for use with petroleum product: SANS 1830

Where HDPE pipe or couplings are used, no mechanical joints shall be allowed. All joints shall be joined by electrofusion welding only, in accordance with SANS 10268-2.

- k) Pipe systems for pressure applications: AS 4176

## **SANS 10087-1:2008**

Edition 5

l) Plastic piping:	ISO 17484-1
m) Pressure pipe:	ASTM F 1281
n) Composite pressure pipe:	ASTM F 1282
k) Pipe flanges:	SANS 1123

## **7.2 Valves**

### **7.2.1 General**

Valves are intended for shutting off the gas supply to (or in) a gas supply line. The valves and valve seats shall be compatible with LPG and certified for use with LPG.

### **7.2.2 Emergency shut-off valves**

Emergency shut-off valves shall be accessible and unobstructed at all times and should be placed as close as possible to where the main gas pipe enters the building. An emergency shut-off valve may be used as an isolation valve on a single appliance installation. It may be placed inside or outside of the building.

### **7.2.3 Isolating valves**

Every fixed appliance shall be equipped with an isolating valve to isolate the individual appliance from the system.

## **7.3 Fixed pipe system**

### **7.3.1 General**

The size of a pipe system should be determined by the maximum gas consumption rate of the appliance(s) to be connected (due regard being given to any potential simultaneous demand) and should be large enough to carry the maximum gas flow without excessive pressure loss in the line.

Figures 6 to 14 are examples of how the gas pipeline can be connected.

Annex H gives typical sizes of connecting pipes that are connected to individual appliances.

### **7.3.2 Regulators**

#### **7.3.2.1 First-stage regulator**

A first-stage regulator delivering an intermediate pressure is normally required where gas draw-off points in an installation are a considerable distance (usually over 9 m) from the container position and the gas demand is heavy. The pressure regulator at the container position is set to deliver at a pressure higher than the appliance operating pressure. This regulator shall be fitted outside of the building as close as possible to the gas supply.

#### **7.3.2.2 Second-stage regulator**

A second-stage regulator shall be installed between the first-stage regulator and the appliance. This second-stage regulator may be installed inside a building, however, if it has a pressure relief valve for gas release, it shall be piped to the outside of the building. The breather hole in a regulator casing does not need to be piped to the outside.

### **7.3.2.3 Single-stage regulator**

For a gas installation under 9 m, a single-stage regulator will suffice. These regulators shall not be installed inside the building unless they are fitted direct to a gas container.

## **7.3.3 Installation and layout of pipework**

### **7.3.3.1 General**

**7.3.3.1.1** The following requirements shall be considered and applied in addition to any similar specific details that might be introduced by the installer:

- a) HDPE pipes shall be used for the conveyance of LPG vapour only, and shall be buried;
  - b) composite pipe is subject to the following requirements:
    - 1) usage above ground is allowed subject to the pipe being protected from direct sunlight;
    - 2) when embedded in walls or floors, no joints shall be allowed in the embedded sections;
    - 3) no joints are allowed in pipe sections passing through cavity walls;
    - 4) use in ceilings is restricted (see 7.3.3.4.2);
    - 5) contact with solvents shall be avoided; and
    - 6) the pipe shall not be closer than 150 mm to any heat source;
    - 7) the pipe shall not be used for liquid supply installations;
    - 8) the maximum supply pressure shall not exceed 150 kPa;
    - 9) the pipe shall not be used as a pigtail or connected directly to a cylinder or appliances such as fireplaces or where the appliance needs to be moved on a regular basis;
    - 10) the crimp shall be compatible with the fitting and pipe and shall be in accordance with the manufacturer's instructions;
- NOTE The preferred type of crimp style for use in South Africa is the "U" type.
- c) schedule 80 steel pipes may, for sizes up to and including 80 mm, be threaded;
  - d) schedule 40 steel pipes may, for sizes up to and including 32 mm, together with all attached fittings, be threaded for vapour application only. For sizes above 32 mm, pipes shall be joined only by welding;
  - e) for liquid applications up to and including 25 mm, nominal bore (NB) pipe shall be schedule 80 steel pipe (for manifolds see annex I);
  - f) where electrical cables are being run on the same wall, gas pipes shall be at least 150 mm apart from the electrical cables and other electrical apparatus. This excludes electric cables in appliances; and
  - g) when threaded connections are used, only taper threads (male and female) shall be allowed.

## **SANS 10087-1:2008**

Edition 5

**7.3.3.1.2** Installations at residential premises that use gas systems with a capacity of not more than 100 kg (2 × 48) kg with a changeover device shall not require plans.

**7.3.3.1.3** Plans and drawings shall preferably be drawn to one of the following scales, however, where permission from the local authority has been obtained, a marked-up drawing or diagram that indicates the manifold, pipeline, and shut-off valve(s), and the required notes for this part of SANS 10087, shall be acceptable:

a) Site plans: 1:1 000, 1:500, 1:300, 1:200, or 1:100.

b) Layout drawings: 1:100, 1:50 or 1:20, provided that in the case of elevations 1:200 may be used.

NOTE The local authority may, in circumstances deemed exceptional by it, accept a scale not provided for in this subclause.

For other information regarding building regulations, refer to the relevant part of SANS 10400.

**7.3.3.1.4** If the building shows any sign of settlement or cracking and in places where expansion joints are applied, the pipework shall be protected against stresses caused by further movement of the building. For example, the pipework should be mounted on wooden battens or ample bends that will allow the pipe to flex without being excessively stressed in the affected area.

**7.3.3.1.5** Gas piping shall not be used as an earth for electrical circuits. Gas piping shall be identified for type or use and appropriately marked with "LPG" every 2 m.

**7.3.3.1.6** In buildings with wooden floors that consist of floor boards supported on joists and in which the piping is installed before the boards are laid, the pipes shall run between and parallel to the joists and shall be provided with proper supports. The usual method of securing the pipes to the side of a joist with clips is recommended. Where this is not possible, they can be laid across the joists in notches, provided that the depth of the notches does not exceed one-fifth of the depth of a joist and their distance from the edge of the nearest support for the joist does not exceed one-sixth of the span between joist supports. Where practicable, notches should have radiused corners, for example, the notches should be formed by cutting into drilled holes. Where pipes cannot be laid parallel to joists and the depth of the joists and the depth of the required notches do not allow the use of a pipe of the required size, a number of smaller pipes of equivalent total capacity can be used (see also 7.3.3.3).

**7.3.3.1.7** Burrs formed when a pipe is cut, shall be removed, and any dust, dirt and scale inside the piping and pipe fittings shall be cleaned out before assembly. During the installation stage, care shall be taken to ensure that the bore of a pipe is not restricted by the entry of any material. While pipe fitting is in progress, all open pipe ends shall be temporarily capped or plugged (with a screwed plug or a cap specifically designed for the purpose) pending extension or completion of the installation. The use of wooden and similar plugs shall be strictly forbidden.

**7.3.3.1.8** Emphasis shall be placed on the need to

a) avoid interference with other installed services,

b) provide reasonable access for inspection, and

c) obviate the exposure of the pipes to abnormally high or low temperatures.

When piping will be laid in positions where abnormally low temperatures can occur, the piping should be lagged.



**7.3.3.2 Buried pipelines**

All pipes shall be installed to a depth of at least 500 mm. For pipelines that are buried, the backfill shall incorporate an approved means (for example, chevron tape placed about halfway between the pipe and the surface) to identify the existence of the pipe. Joints in steel pipelines shall be made by welding or brazing. Joints in copper pipes shall comprise soldered capillary fittings (see SANS 1067-2) or be hard-soldered. All buried pipes shall be corrosion protected in an approved manner.

All other joints that are not welded, soldered or electrofusion joints (for example mechanical joints) shall be available for maintenance and shall not be buried.

**7.3.3.3 Concealed pipework**

**7.3.3.3.1** If a gas installation is required in a building that has floors of concrete or other solid material, where the building plans are required (see 7.3.3.1.2), they shall indicate one of the following concepts:

- a) ducts/trenches of approved depth; or
- b) sleeves; or
- c) fully embedded pipes.

**7.3.3.3.2** When pipes are chased in a concrete floor,

- a) they shall require floor plans,
- b) they shall be placed at least 50 mm below the top of the concrete,
- c) all joints in steel pipes shall be welded,
- d) all joints in copper pipes shall be soldered,
- e) no mechanical joints shall be buried or embedded in floors or walls, and
- f) steel and copper pipes shall be protected against corrosion in an approved manner.

NOTE Protection may mean an electrical conduit for copper tubing, or a wrapping for copper or steel piping, or plastic coating, etc.

**7.3.3.3.3** Pipes that are to be embedded in concrete before the completion of a floor shall

- a) not have any type of mechanical joint,
- b) require floor plans,
- c) when steel or copper piping is used for this purpose, be protected against corrosion in an approved manner, and
- d) be placed at least 50 mm below the top of the concrete.

**7.3.3.3.4** If a system of ducts is used, ventilation to open air shall be provided at the lowest point.

**7.3.3.3.5** Branches in pipelines shall be developed with the use of standard wrought steel pipe fittings.

**7.3.3.3.6** Where copper pipes are required to pass through any wall, they shall be sleeved.

**7.3.3.4 Pipes in critical locations**

**7.3.3.4.1** Critical locations are locations where gas cannot be vented freely to the atmosphere. Examples of these locations are the cavities of cavity walls, lift shafts, flues, ceiling voids or air ducts.

**7.3.3.4.2** Pipes shall not pass through the cavity of cavity walls or through lift shafts, flues, ceiling voids or air ducts unless they are designed and constructed in accordance with an approved standard applicable to critical locations. Pipes that pass through critical locations shall be welded. Where pipes pass through walls that might or might not be regarded as cavity walls, such pipes shall be sleeved.

**7.3.3.4.3** Where copper tubes are used, they shall have no joints and shall be sleeved. The sleeve shall be a steel tube that complies with SANS 62-1.

**7.3.3.4.4** Gas pipelines should not be installed in any dedicated emergency route. However, where approval from the local authority has been granted for installation in emergency routes, the pipe shall be schedule 40 piping, be of welded construction (see also 7.3.3.4.7), have no joints and shall be for vapour use only.

**7.3.3.4.5** Gas piping shall not be laid in the same service as “Electrical Bus-Bars”.

**7.3.3.4.6** Gas piping shall be at least 150 mm away from any electrical cables where they run parallel to each other (see also 7.3.3.1.1(f)). Gas piping may cross electric cables or vice versa, provided that these do not come into contact with each other and there are no joints in either line within 150 mm of such crossings.

**7.3.3.4.7** The pipes listed in 7.1.2 may be installed in critical locations, provided that no mechanical joints shall be made within these areas. Where pipes are to be welded, a competent person (welder) shall undertake this work.

**7.3.3.4.8** Where pipes are installed in accordance with the requirements of 7.3.3.4.7, a pressure test of at least 400 kPa shall be done to ensure that no leaks are in the system. The pressure shall be maintained for at least 15 min to ensure that no pressure drop occurs.

**7.3.3.5 Supports and fixings for pipework**

**7.3.3.5.1** Piping shall be firmly supported, and particular attention shall be given to the strength and security of hangers and similar supports.

**7.3.3.5.2** The intervals between supports and fixings shall be as given in tables 4 and 5.

**Table 4 — Intervals between pipe supports for copper pipes**

1	2	3
Nominal size of pipe mm	Maximum interval between pipe supports m	
	Vertical runs	Horizontal runs
8	1,2	0,6
10	1,5	0,9
15	1,8	1,1
20	2,4	1,8

**Table 5 — Intervals between pipe supports for steel pipes**

1	2	3
Nominal size of pipe mm	Maximum interval between pipe supports m	
	Vertical runs	Horizontal runs
10	1,8	1,2
15	2,4	1,8
20	3,0	2,4
25	3,0	2,4

**7.3.3.5.3** A support shall be provided within 150 mm of each pipe fitting. Supports shall be provided adjacent to each bend in a pipe. Heavy components installed in the pipeline (for example, regulators, changeover valves, and manifold valves) shall be supported independently of the pipeline. On single applications where the joint is made between the hose and the pipe, the pipe shall be supported at that joint. Proper saddles (steel or brass) should be used and not PVC saddles as these become brittle due to UV radiation and break easily.

**7.3.3.5.4** To allow for the use of tools on a joint without damaging the supporting surface, pipework and supports shall be so arranged that joints stand clear of the surface on which they are supported.

#### **7.3.3.6 Disconnection and clearing**

Pipe runs require enough connectors or unions to allow the removal or alteration of lengths of pipe with minimum damage to the structure and surrounding decorations. To effectively purge a pipeline, appropriate gas bleeding arrangements shall be included in the pipeline, if not available on the appliance.

#### **7.3.3.7 Reduction of resistance to flow**

To prevent restriction of gas flow, the number of pipe fittings shall be kept to a minimum, and sharp changes of direction shall be avoided. A bend in a pipe shall be of radius at least five times the diameter of the pipe and shall be free from kinks. When fittings are used to cause a change of direction, bends shall be preferred.

#### **7.3.3.8 Separation of occupancy and tenancy**

When pipes pass through sleeves or apertures in a fire-resistant structure, the space between the pipe and the sleeve or aperture shall be solidly filled with a water-resistant, non-abrasive, fire-resistant, non-corrosive material, and the duct or channel shall be completely sealed with fillings of fire resistance at least equal to that of the surrounding structure. Every filling or seal subsequently disturbed shall be restored to its original condition. Provision shall be made for the expansion of pipes between fixed points. PVC sleeves shall not be used in this instance.

#### **7.3.3.9 Position of fixed gas supply points**

**7.3.3.9.1** Each gas supply point shall be situated to suit the position of the appliance that it serves, and shall allow for convenient coupling to the appliance. Until the appliances are connected, each point shall be securely capped or plugged, and so marked as to indicate that it is a gas point. Where the appliance is removed from the system in use, such a gas point shall also be capped or plugged.

**7.3.3.9.2** The gas supply point to a built-in space heater shall be as recommended by the manufacturer.

**7.3.3.9.3** Each point intended for connection to an appliance shall have a shut-off valve.

**7.3.3.9.4** Shut-off valves shall be accessible at all times.

## **7.4 Joints and fittings (cocks, valves and unions)**

**7.4.1** Except for welded, soldered or electrofused joints, all joints, cocks, valves and unions (including the unions on gaslight fittings) shall be readily accessible for maintenance and repair, and all joints shall be so made as to avoid undue strain in the pipe system.

**7.4.2** Compression-type and capillary-type jointing are recommended for copper piping. Brazed or silver soldered joints are also acceptable. Only soft solder that complies with S19 and S20 of SANS 24 shall be used for capillary fittings. Where compression fittings are used, they shall only be used with class II copper pipe.

**7.4.3** Joints in steel pipes can be made by welding, brazing or screwed connection (see also 7.3.3.1.1). Only a competent person, who can provide proof of competency in welding, shall carry out welding and brazing.

**7.4.4** In the case of tapered screwed connections, both male and female threads shall be tapered. Particular care shall be taken to ensure that mating screw threads are of the same type, form and designation. No joint shall be made by over-torque of unmating threads or by relying on the jointing compound for sealing.

**7.4.5** Only approved jointing material shall be used on male threads of screwed components. Hemp shall not be used.

**7.4.6** Washers, gaskets and joint rings used for flanged joints shall be strong, gas-tight, durable and shall comply with at least SANS 974-1.

**7.4.7** In installations involving a number of branch lines, each branch line shall have a shut-off valve to allow its repair without shutting off the whole installation.

## **7.5 Flexible tubing and hose**

**7.5.1** Appliances that have to be moved for cleaning shall be connected to the gas system by flexible tubing or hose (see 6.2.3).

**7.5.2** Flexible tubing or hose can also be used for simple single container installations in which the container is located indoors and directly connected to one appliance by means of a regulator.

**7.5.3** The length of a flexible tube or hose shall not exceed 2 m, and flexible piping shall not extend from one room to another or pass through any wall, partition, ceiling, window or floor.

**7.5.4** Flexible tubing and hose shall be installed away from any position of mechanical damage and in a position where it can be inspected at appropriate intervals (see 10.1).

**7.5.5** Only approved types of nozzle (see SANS 1237) shall be used as end connections. The ends of the tubes or hoses shall fit tightly over the inlet part of the nozzle.

**7.5.6** All hose shall be clamped in position on the nozzle with a hose clip.

**7.5.7** Flexible tubing and hose shall not be exposed to heat in excess of 50 °C. Particular care shall be taken when connecting a gas stove or a hotplate to ensure that the run of tubing or hose is kept well below the level of the open burners. The tubing or hose shall also be kept well clear of the oven vent and should not be taken around the back of the stove or flue outlet.

**7.5.8** Each connecting tube or hose shall be in one piece and shall supply only one appliance, i.e. there shall be no joints or T-junctions along its length.

**7.5.9** Flexible tubing and hose shall be checked for signs of rupture, cracking and perishing, and shall be replaced if necessary. If over five years old and exposed to UV light, flexible tubing and hose shall be replaced automatically.

**7.5.10** For manifold hoses see annex I.

## **7.6 Provision of flues**

**7.6.1** The provision of flues on appliances is covered in SANS 1539 and flues shall be installed in accordance with the requirements of SANS 1539 and this subclause. (See also annex E.)

**7.6.2** A space heater, unless designated as a vent-free heater in terms of SANS 1539, shall be flued to the outside air when

a) the output rating of the heater exceeds 16 MJ/h, and

b) the ratio of the input rating of the appliance(s) to the volume of the room exceeds  $365 \text{ kJ/h/m}^3$  of free room space.

**7.6.3** Except as allowed in terms of 7.6.5, all appliances other than space heaters shall be flued to the outside air when the ratio of the total input rating of all the appliances in the room to the volume of that room exceeds  $0,37 \text{ MJ/m}^3$  of free room space.

**7.6.4** In the case of vent-free heaters, no flues are required (see 7.6.7) however, the heaters shall be installed in accordance with the manufacturer's requirements, 6.3 and relevant subclauses. (See also annex E.)

**WARNING** If instantaneous water heaters (geysers) without a balanced flue system are fitted in bathrooms, permanent ventilation is of the utmost importance because of the high gas consumption rate of the appliance, the small size of normal bathrooms, and the tendency of most users to keep air entry into a bathroom to a minimum.

**7.6.5** If two or more appliances that are not in the categories described in 7.6.2 and 7.6.3 are located in the same room, one or more shall, if applicable, be so flued as to ensure that the ratio given in 7.6.3 shall not be exceeded.

**7.6.6** Gas stoves, hotplates and sink water heaters installed in kitchens may be exempted from the requirements of 7.6.3 and 7.6.4 if they are to be used at maximum rating for short periods only. However, kitchens shall be adequately ventilated by the use of at least one airbrick (in an external wall) that has a ventilating area of at least  $160 \text{ cm}^2$ .

**7.6.7** Appliances that have a high rate of gas consumption or that operate for long periods shall be equipped with flue pipes that lead to the outside air (see 6.3). Typical examples of such appliances are multipoint and bath-size water heaters, showers and high-output space heaters.

### **WARNINGS**

**1** LPG appliances consume oxygen and, in enclosed or restricted spaces, this will cause the depletion of the oxygen content of the available air.

**2** Although the exhaust gases from an LPG burner (i.e. nitrogen, water vapour and carbon dioxide) are clean, colourless and non-toxic, they can cause heavy water condensation

## **SANS 10087-1:2008**

Edition 5

inside a room if the ventilation is inadequate. Moreover, too much carbon dioxide in the air might upset the performance of an LPG appliance and lead to the formation of carbon monoxide, which is highly toxic.

**3 All LPG appliances that are likely to need a flue, have connections for a flue pipe. In most cases, the appliance will incorporate a draught diverter, the purpose of which is to prevent downdraughts that might cause the accidental blowing out (extinguishing) of the burner flames.**

**4 Permanent ventilation shall be provided for appliances that require a flue to be fitted (see annex E).**

**7.6.8** A flue or vent shall not be connected to a chimney leading from a fireplace unless the bottom of the chimney is permanently sealed. Where a flue pipe is extended into an existing sealed chimney, care shall be taken to ensure that the end of the flue pipe does not protrude into the chimney space and that the chimney is free from soot etc. Brick and masonry chimneys shall be so treated as to obviate condensation problems.

**7.6.9** A flue shall be clear of all obstructions that might impede the flow of exhaust gases, and the cross-sectional area of the flue shall nowhere be less than that of the flue collar on the appliance. A flue pipe shall not enter into a draught diverter far enough to cause an obstruction.

**7.6.10** Dampers and an excessive number of bends or sudden changes in the size and shape of the cross section of flues shall not be allowed.

**7.6.11** Where two or more appliances are vented into a common flue, the individual flue pipes shall be joined by Y-pieces situated at the greatest practicable height above the appliances. The cross-sectional area of the common flue pipe shall be at least equal to the combined area of the flue collars on the individual appliances.

**7.6.12** A flue pipe shall run as near to the vertical as possible throughout its full length. Horizontal runs are not recommended and shall be kept to a minimum and be as short as possible. Joints in the flue shall be so constructed that condensate cannot seep through the joint and out of the flue.

**7.6.13** Where horizontal runs cannot be avoided entirely, the horizontal sections shall be positioned as far above the appliance as the layout will allow, and their total length shall not exceed 75 % of the total vertical run. The horizontal pipes shall also rise slightly towards the flue outlet (enough to ensure that any water that might condense in the flue will drain back towards the appliance).

If the use of bends in a flue is unavoidable, a bend of 45° is preferred. Where, however a 90° change in direction is unavoidable, a 90° bend with a radius of at least three times the flue diameter shall be used.

**7.6.14** The flue outlet shall be so positioned as to prevent downdraughts. Frequently this means that the outlet shall be above the highest point on the building, for example, approximately 1 m above the roof ridge or, in the case of a flat-roofed building, 1 m above the parapet. The outlet shall have a rainproof terminal or cowl of a type that does not restrict the flue. This cowl shall be screened to prevent birds from nesting in it.

**7.6.15** Overcooling of flue pipes might cause reduction of draught or heavy condensation inside the pipes (or both), therefore flues shall be run indoors as far as possible and thermally insulated where necessary. If cooling and condensation are likely to be a problem, a condensate trap shall be fitted at a convenient point low down in the flue.

**7.6.16** The entire flue installation shall be completely fire resistant. Flue pipes shall be so secured that they stand clear of walls and ceilings, and wherever they pass through a ceiling, sleeves and ceiling plates shall be fitted.

**7.6.17** When a flue pipe system is designed, careful consideration shall be given to the danger of a flue causing the overheating of woodwork or other combustible material in a building. Where necessary, a fire-resistant, heat-insulating screen shall be fixed between the flue pipe(s) and the combustible materials to ensure that the surface temperatures of the latter do not rise above 65 °C. The clearance between any such screen and the flue pipe(s) shall be at least 10 mm.

**7.6.18** Flue pipes shall be securely fixed and supported and, when possible, should extend through a roof. Where a flue pipe passes through a roof or an outside wall, the junction shall be rendered fully weatherproof and fire-resistant, and the materials used to effect this shall, in addition, be corrosion resistant.

**NOTE** If it is inconvenient or impossible for a flue pipe to pass through a roof (i.e. if it has to be taken through a wall), a vent tile or other approved wall terminal may be used provided that it is properly positioned. Alternatively, where the eaves permit, the flue may have a vertical section (riser) that is fitted with a suitable terminal that does not obstruct or reduce the effective cross-sectional area of the flue or vent outlet.

## **8 Inspection, testing and instructions to users**

### **8.1 Inspection and testing of new installations**

#### **8.1.1 General**

On completion, and before commissioning, the installation shall be inspected, tested and approved by the registered installer, and the user shall be issued with a certificate of compliance that indicates that the installation has been tested and that it complies with this part of SANS 10087. A copy of the certificate of compliance shall be sent to a body appointed by the Chief Inspector of the Department of Labour for record purposes and, where required, to the local authority.

Installations shall be tested in the following sequence:

- a) high-pressure stage;
- b) intermediate-pressure stage (when used); and
- c) low-pressure stage.

#### **8.1.2 High-pressure stage**

The valves and high-pressure connections shall be tested for leaks. A test method applicable to a twin container installation is described in annex J and shown in figure J.1.

#### **8.1.3 Intermediate-pressure stage (when used)**

An intermediate-pressure stage shall be tested, with inert gas, air or nitrogen, at a pressure of 200 kPa for a minimum period of 10 min. Before this test is carried out, the outlet of the secondary pressure regulator shall be closed.

#### **8.1.4 Low-pressure stage**

The complete low-pressure stage shall be tested in accordance with an acceptable method (see annex K for one method of testing). The pipe system can be tested separately first, or the installation can be tested as a whole. When the system is purged of air, precautions shall be taken to avoid hazardous accumulation of gas.

## **8.2 Instructions to users**

**8.2.1** On completion of the installation, the registered installer shall provide a certificate of compliance to the user.

**8.2.2** The following markings shall be permanently displayed in a prominent position on or near the installation:

- a) the installer's name;
- b) the date of installation; and
- c) the installer's registration number.

**8.2.3** The registered installer or authorized company representative shall supply the user with a printed instruction sheet or booklet describing the correct and safe handling of the LPG systems and appliances, and appropriate general emergency procedures.

In particular, attention shall be drawn to

- a) the changing of containers and the risks involved,
- b) the action to be taken to disperse accidental accumulation of gas,
- c) the action to be taken in case of fire (see also 8.3.12), and
- d) the fact that the so-called "empty" containers can be dangerous and shall be kept closed at all times.

All the above details shall be discussed with the user to ensure that he fully understands all the details. His attention shall also be drawn to the information and warnings (when relevant) given in the product brochures supplied with the appliance.

**NOTE** Users should contact the local authority to find out if they need a Flammable Liquids Permit. This permit is usually required when storing gas on the premises.

## **8.3 Fire prevention — Design, instructions and training**

**8.3.1** The local fire department shall be consulted at an early stage when LPG storage is planned on a site.

**8.3.2** The user shall be advised regarding the use of approved fire protection appliances and when to use such appliances. The acquisition and installation of a dry powder fire extinguisher of size at least 9 kg that complies with SANS 1910 shall be required for installations of combined capacity in excess of 100 kg of gas. The extinguisher shall be installed near to the installation. It shall be securely mounted and its position shall be indicated in an approved manner with appropriate symbolic signs.

**8.3.3** Loose or piled combustible material and weeds and long grass shall not be permitted within 3 m of any container.

**8.3.4** When relevant, means such as dikes, diversion curbs, or grading shall be used to prevent the accumulation of flow of liquids that have flash points below 93,4 °C under LPG containers.

**8.3.5** LPG containers shall be located at least 3 m from the centre line of the wall of bunded areas containing flammable or combustible liquids.



**8.3.6** Where LPG installations are closer than 3 m to any other compressed gas, special fire protection precautions shall be considered, for example, a firewall.

**8.3.7** No part of an LPG container shall be located in the area 1,8 m horizontally from a vertical plane beneath overhead electric power lines that are over 600 V.

**8.3.8** Structures such as firewalls, concrete barriers, and other similar structures shall be avoided around or over installed containers. A maximum of two walls joined perpendicularly shall be allowed.

**8.3.9** The planning for effective measures for the control of inadvertent LPG release or fire shall be co-ordinated with local emergency handling agencies, such as fire departments. Planning shall consider the safety of emergency personnel.

**8.3.10** In extreme fire risk situations, the provision of a fire hose reel may be required by the local fire department.

**8.3.11** Access to and around the installation shall be provided for fire-fighting purposes and this area shall be kept free of obstacles at all times.

**8.3.12** People on premises where LPG is stored shall receive instructions and training in accordance with the requirements of the Occupational Health and Safety Act, 1993 (Act No. 85 of 1993) to enable them to understand fire precautions and the actions to be taken in the event of fire or leakage of LPG.

Those training to fight LPG fires shall be aware that these fires should not normally be extinguished unless the source of LPG can be isolated. At commercial and industrial sites, notices setting out the emergency procedures shall be prominently displayed near the LPG storage area. At domestic installations, the user shall be provided with full instructions which include the actions to be taken in an emergency.

**8.3.13** Fire protection in major gas installations can be carried out in terms of a rational design as described in SANS 10400.

## **9 Electrical equipment and other sources of ignition**

### **9.1 General**

Where electrical equipment is placed within the safety distance as specified in figure 3, the zone requirements in accordance with SANS 10087-3 shall apply.

Electrical equipment, such as light switches and plugs, shall be at least 200 mm away from any burner and potential point of gas release. Where it is necessary to install a gas hob together with an electric oven, a three-point plug socket shall not be used to connect the electric oven. A proper isolator switch shall be in place above the level of the hob and it shall have at least 200 mm clearance from the hob.

No electrical connection shall be made below the hob. See figures 15 and 16 for further connections.

### **9.2 Safety requirements**

Figures 15 and 16 are examples of installations in kitchens and show where electrical plugs shall be placed in relation to a gas hob and electrical oven.

NOTE There is a safety shut-off valve on the incoming gas line.

## **10 Ongoing inspection and repair**

### **10.1 Inspection**

The user shall ensure that appliances, components of the installation and the distributing system are inspected at regular intervals (not exceeding five years) to ensure that all components are still operating effectively and that the system is leak free. All hoses used on outdoor installations shall be replaced five years after the date of installation.

### **10.2 Supplier of gas and equipment**

The supplier of gas and gas equipment shall inform the user of his responsibilities in respect of safe operation, use and maintenance of the gas and equipment (see also the Occupational Health and Safety Act, 1993 (Act No. 85 of 1993) for duties of the supplier).

### **10.3 Repair**

The incorrect repair (or adjustment) of the various components of an LPG installation can result in hazardous conditions. Only a registered installer or a registered appliance technician, as appropriate to the appliance being installed, shall therefore carry out such repair. This also includes the removal of appliances from a gas system.

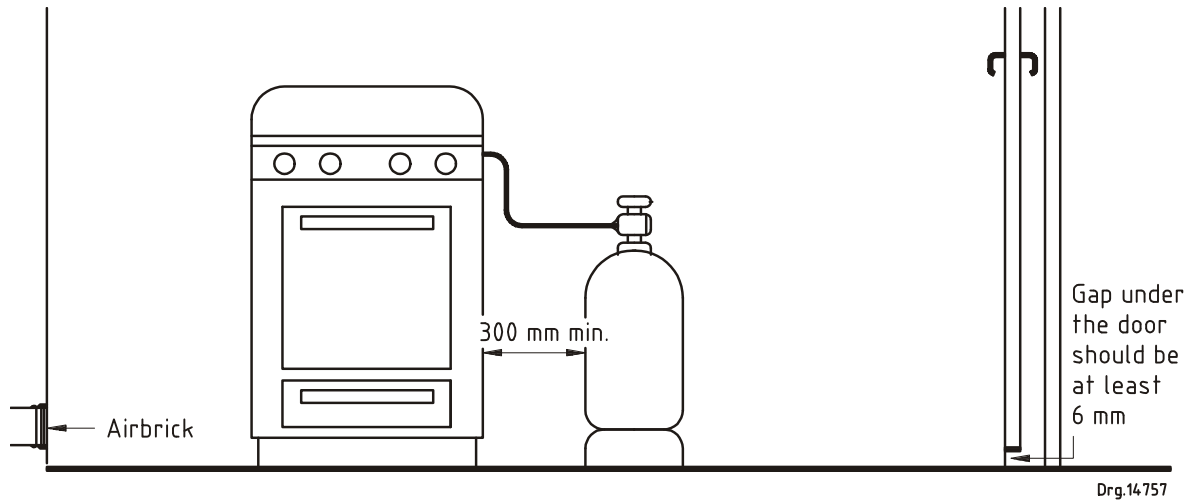


Figure 1 — Ventilation at floor level

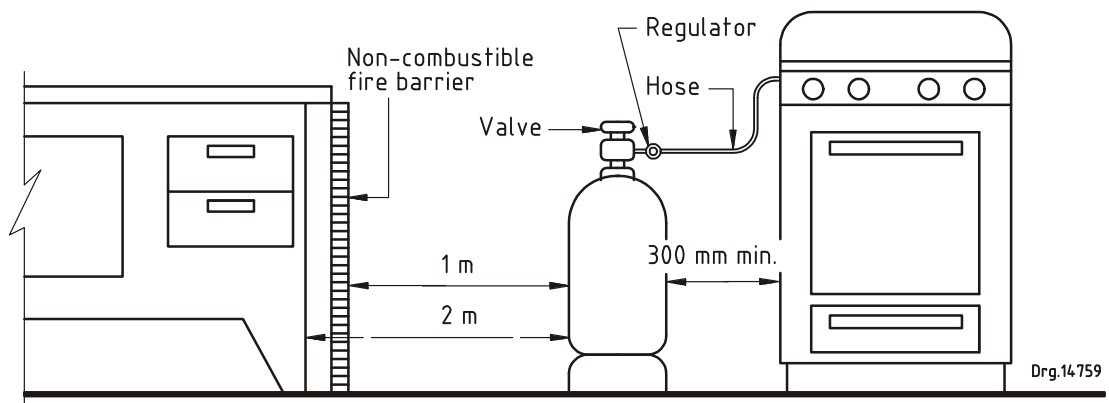
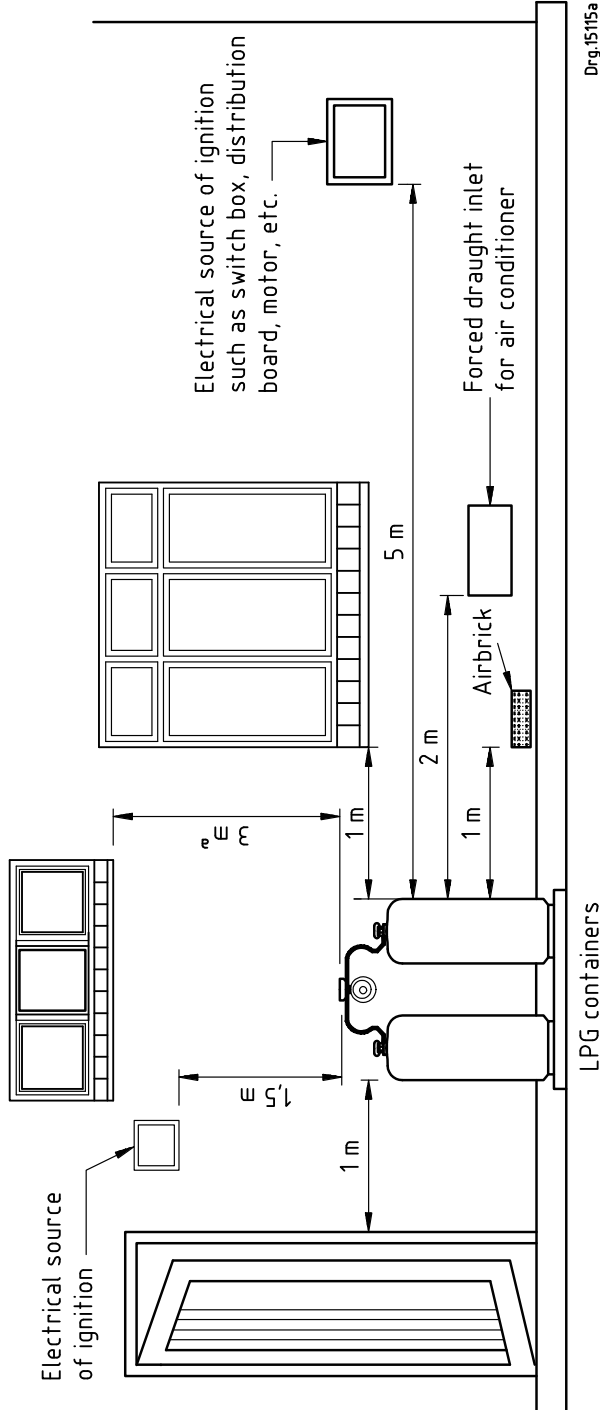
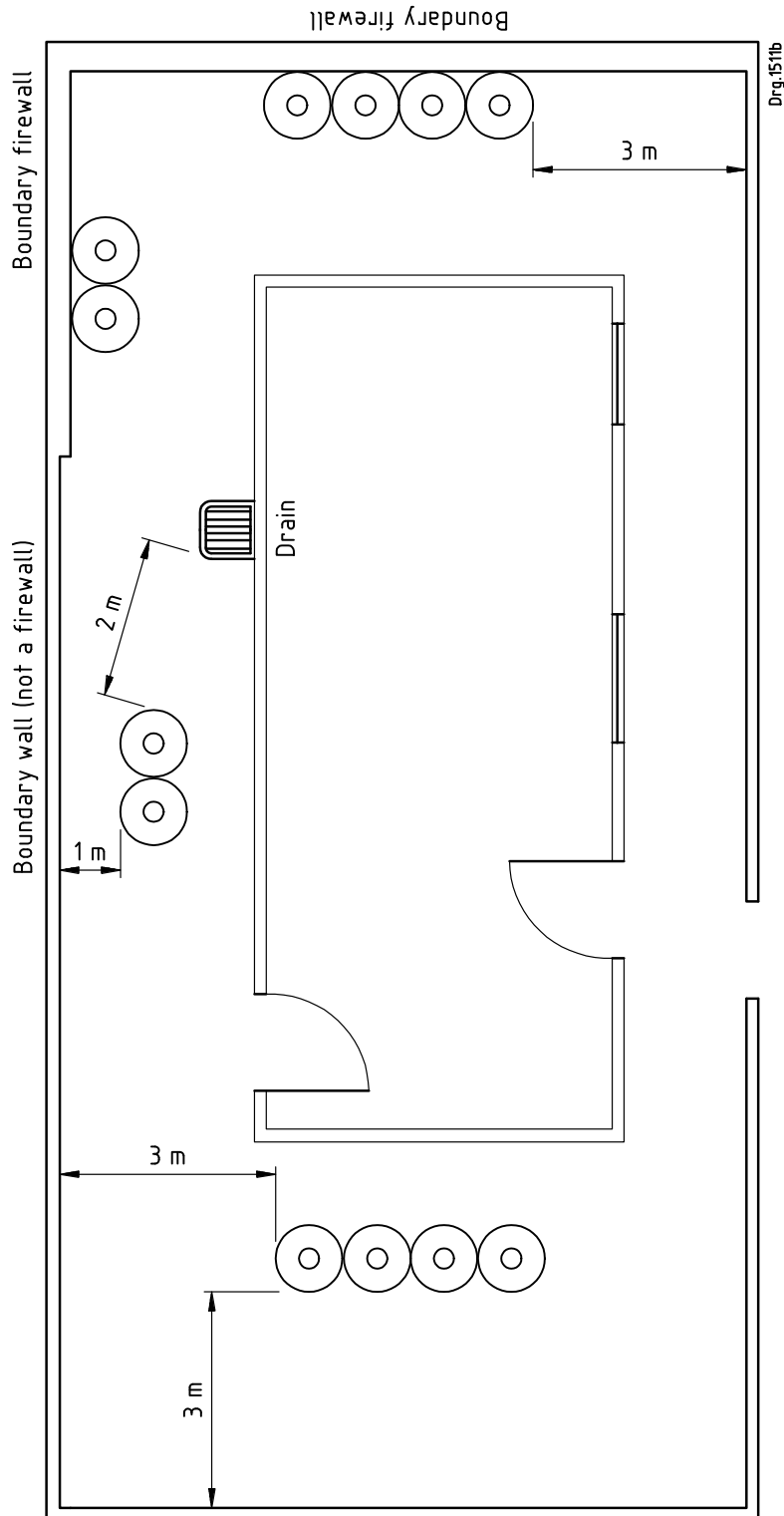


Figure 2 — Containers and coal stoves



a May be reduced to 300 mm provided a non-combustible roof is installed between the containers and the window.

**Figure 3 — Minimum safety distances**

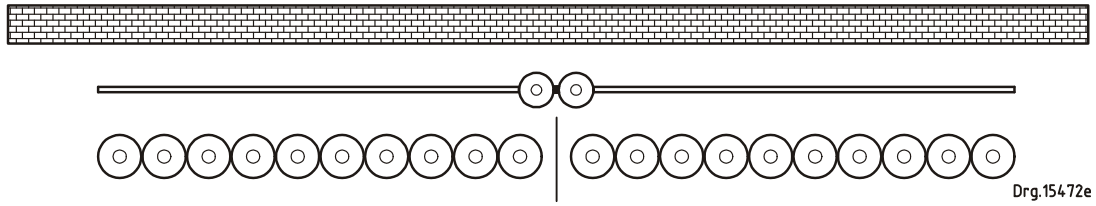


NOTE 1 The minimum required distance from drains is 2 m, irrespective of the number of cylinders.

NOTE 2 Where not more than two cylinders are used, the minimum distance from a boundary is 1 m, unless the boundary is a firewall, in which case the cylinders may be placed directly against the boundary.

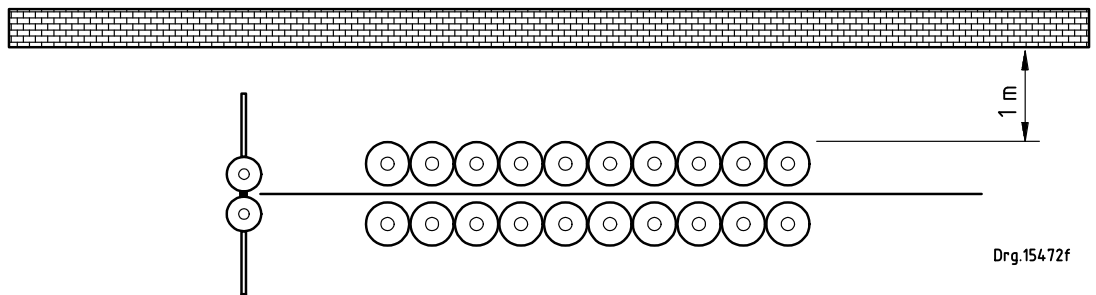
NOTE 3 Where more than two cylinders are used, the minimum distance from a boundary is 3 m, unless the boundary is a firewall, in which case the cylinders may be placed directly against the boundary.

Figure 4 — Minimum distances



Series arrangement set of containers with a maximum of 10 + 10 of 48 kg capacity  
or a set of 3 + 3 dumpies of 500 L capacity

**a) Series arrangement**



Parallel arrangement sets of back to back containers to a maximum of  
10 per branch of 48 kg capacity

**b) Parallel arrangement**

**Figure 5 — Typical arrangement of manifolded cylinders**

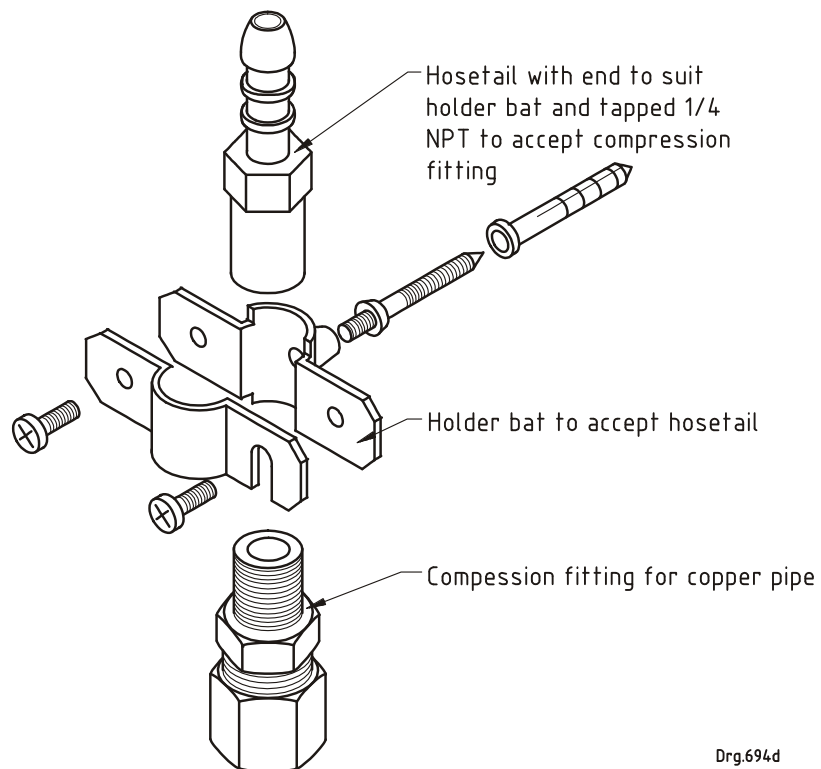


**Figure 6 — Alternative method for single cylinder connection**



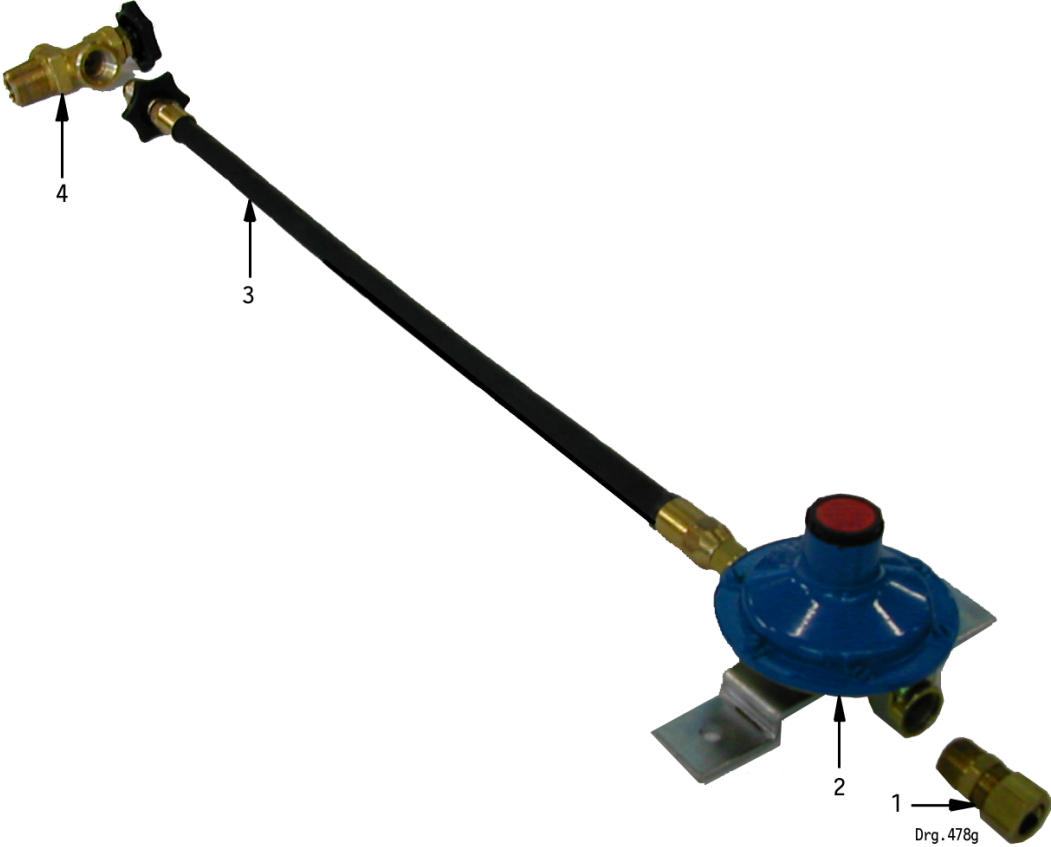
Drg.478k

**Figure 7 — Alternative method for single cylinder connection that shows various components**



Drg.694d

**Figure 8 — Wall-mounted connection for alternative single connection**



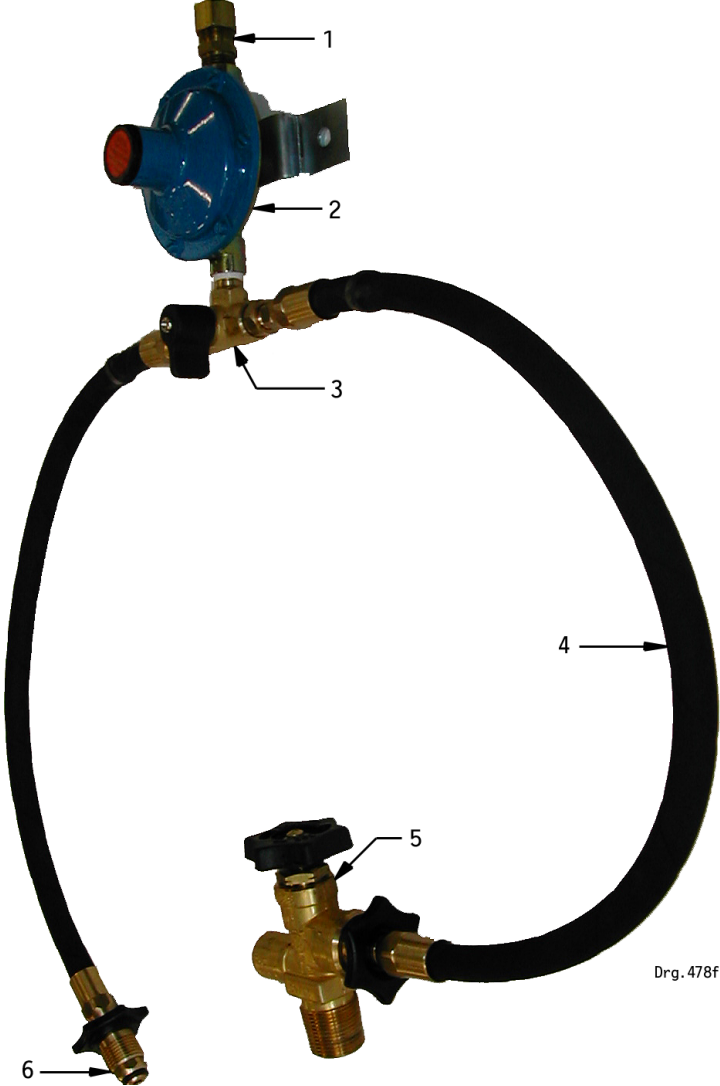
- Key
- 1 Copper pipe connector
  - 2 Regulator
  - 3 Pigtail
  - 4 Cylinder valve

Figure 9 — Application for single cylinder connection



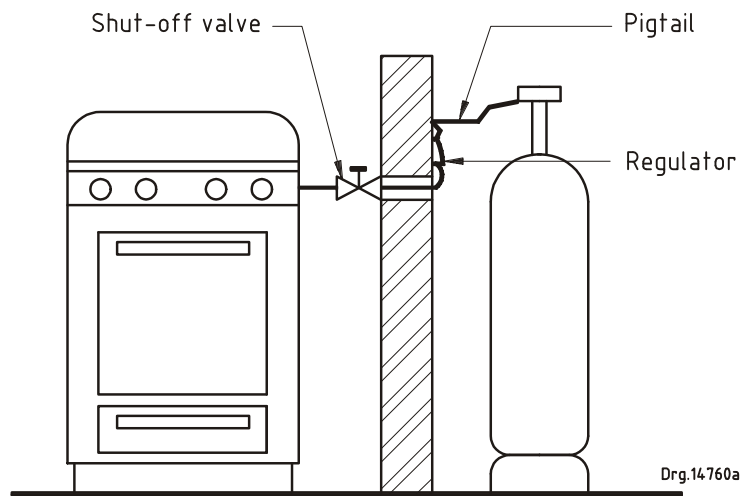


Figure 10 — Application for single cylinder connection that shows various components



- Key
- 1 Copper pipe connector
  - 2 Regulator
  - 3 Changeover device
  - 4 Pigtail
  - 5 Cylinder valve
  - 6 Connection into cylinder valve (bullnose)

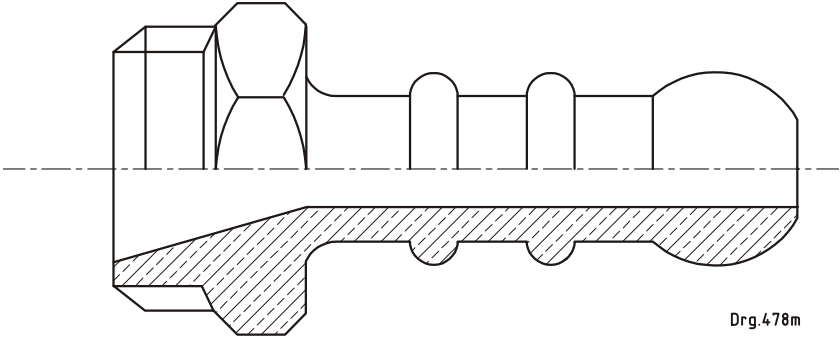
Figure 11 — Application for dual cylinder connection with changeover valve



**Figure 12 — Complete connection**



**Figure 13 — Application for dual cylinder connection that shows the regulator**



Drq.478m

**Figure 14 — Hose connector**

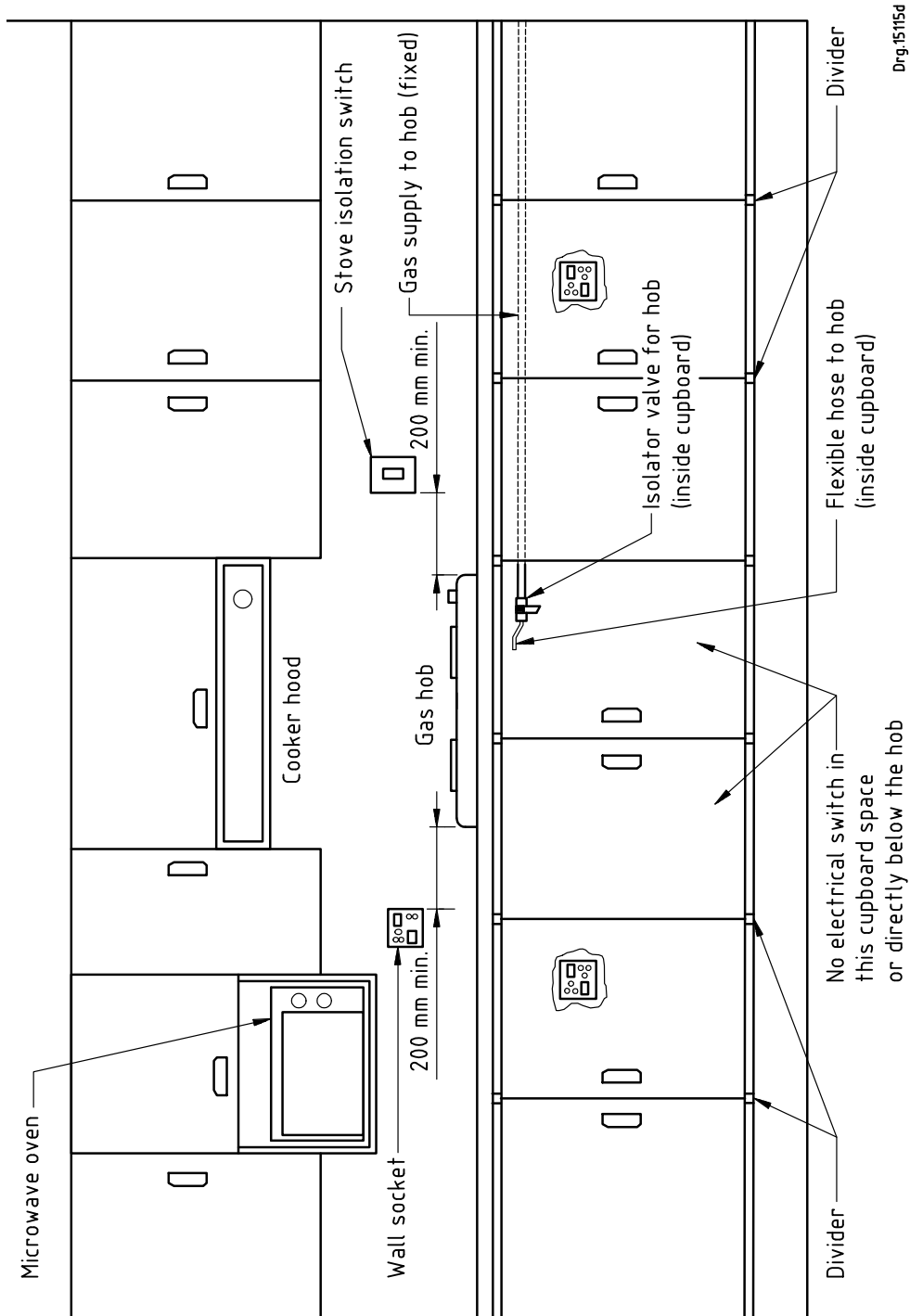
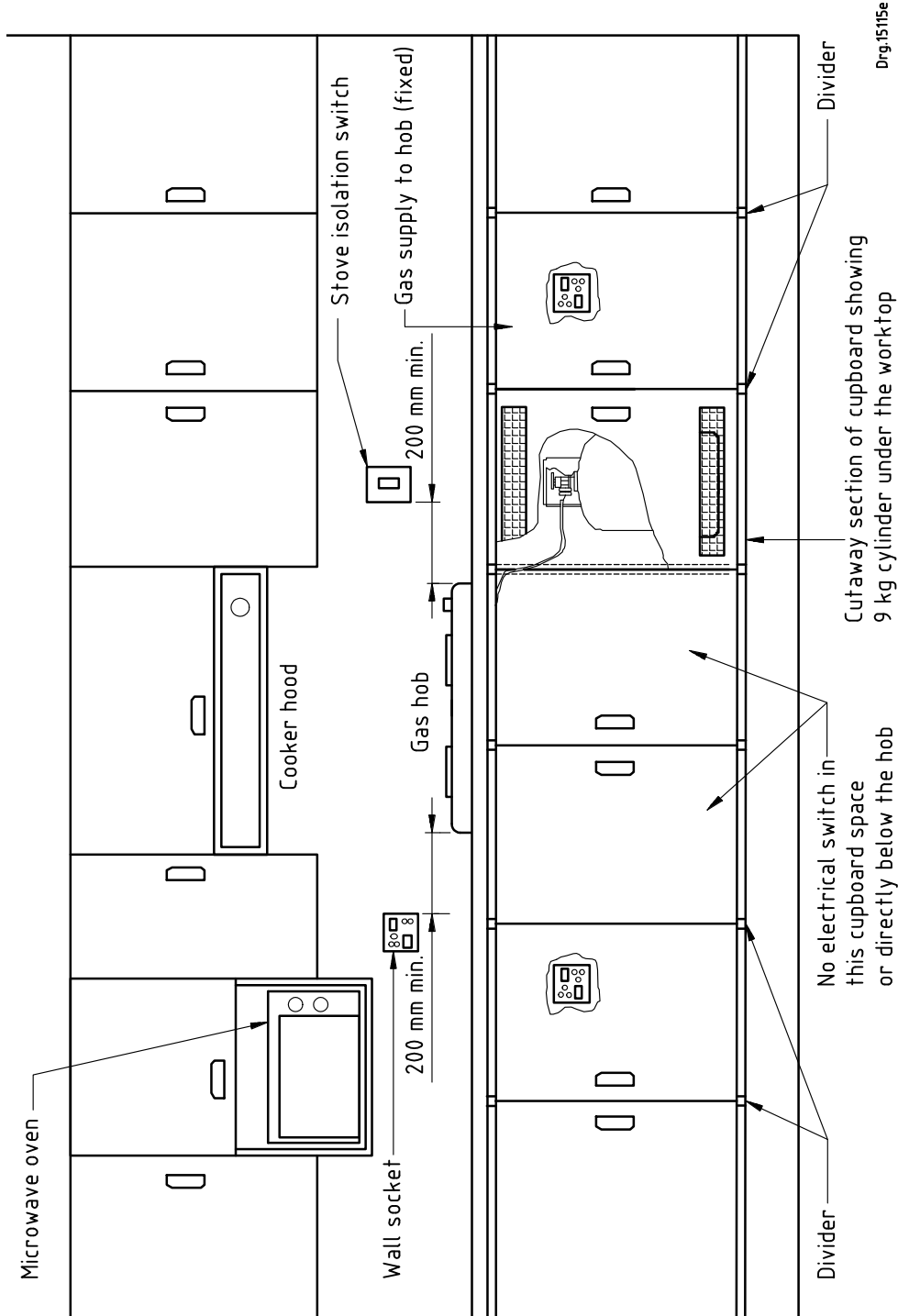


Figure 15 — Typical installation by means of a flexible hose and solid pipe



NOTE The hose goes through the solid partition and there are ventilation slots at the top and bottom of the cupboard door. If the worktop/cupboard installation is placed against an outside wall of the kitchen, a ventilation slot should also be placed on the outside wall at the bottom level of the cupboard.

Figure 16 — Typical installation for gas cylinder directly connected to hob by means of a flexible hose

## Annex A (informative)

### Relationship between volume and mass of LPG

The relationship between volume and mass of LPG (see figure A.1) should be based on the following relative density values:

Commercial butane	0,583
Commercial LPG mixture	0,555
Commercial propane	0,508

NOTE 0,555 is based on a 50/50 mixture of butane and propane.

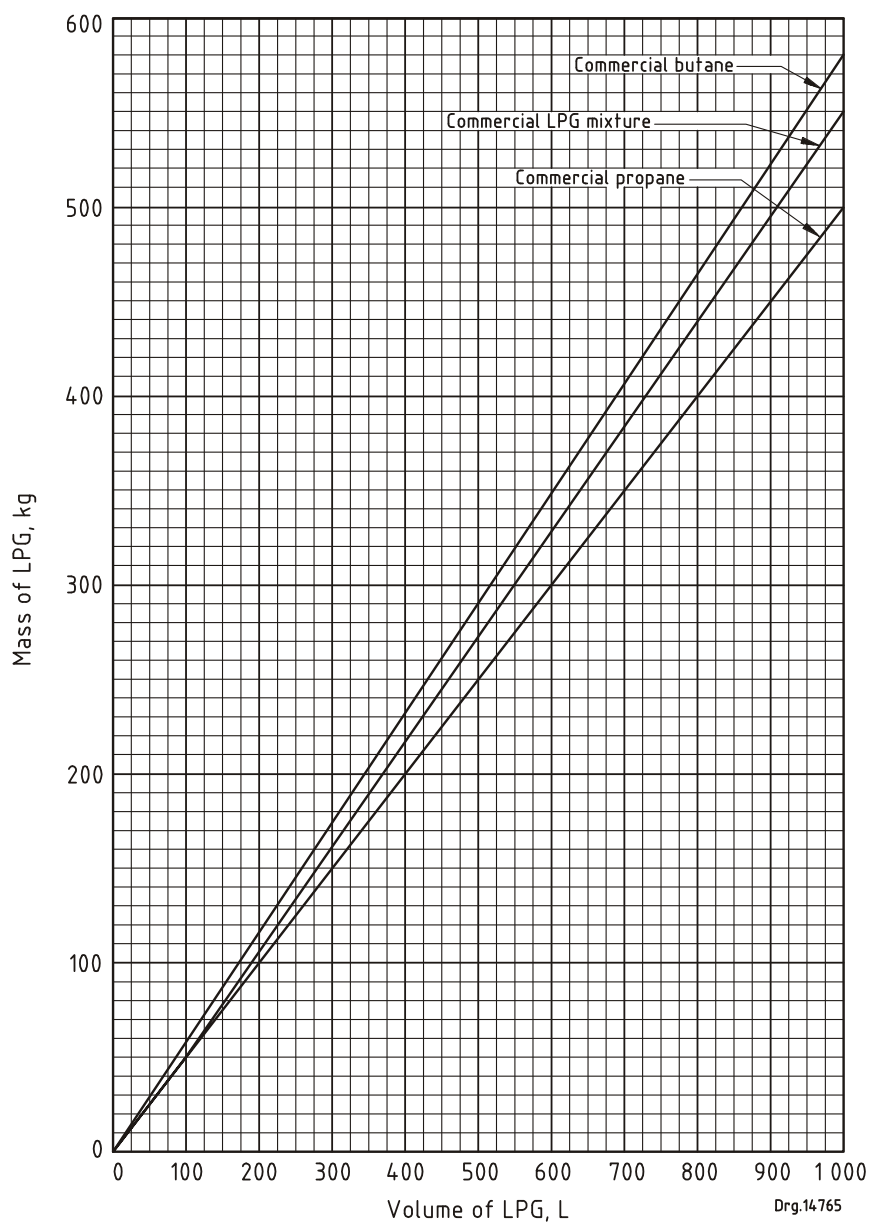


Figure A.1 — Relationship between volume and mass of LPG

**Annex B**

(normative)

**In-situ container (dumpies) filling requirements**

Containers (dumpies) can be filled in situ subject to the following conditions:

- a) an individual container (dumpie) shall have a water capacity in excess of 120 L;
- b) each container (dumpie) shall be fitted with an approved pressure relief device;
- c) each container (dumpie) shall
  - 1) have an automatic shut-off valve which should operate at the maximum allowed liquid level applicable to the container being filled (this should be complied with when the containers being filled are on a manifold with a single filling connection), or
  - 2) be fitted with a permanent fixed liquid level gauge device so that the relevant mass fill ratio shall not be exceeded for the particular container size;

NOTE This filling method can be allowed subject to a quantified assessment of the vapour release and to subsequent approval by the local authority.

- d) filling trucks shall be at least 3 m away from any container;
- e) where no fixed filling point is provided but filling is done individually, such container shall be at least 3 m away from the wall;
- f) no person shall fill a container with gas (see requirements given in SANS 10019) unless
  - 1) he is fully conversant with the relevant subclauses of this part of SANS 10087,
  - 2) he is satisfied that the container complies with the requirements of an approved manufacturing specification or the provisions of an approved manufacturing code (if necessary, this may be ascertained from the relevant container documents),
  - 3) he employs staff trained and experienced in the pre-filling inspection and actual filling of containers with those gases that he handles,
  - 4) the container is not due for periodic inspection or testing, and
  - 5) permission to fill the container has been granted by the owner of the container;

NOTE This precaution is solely for safety reasons, since the cylinder containment history is an essential reference for correct filling.

- g) for classification and electrical zoning, see SANS 10087-3.



## **Annex C**

(informative)

### **Determination of adequacy of gas supply**

#### **C.1 Purpose**

The main purpose of this determination is to ensure that the gas piping is correctly sized.

**NOTE** For a single-container or dual-container system, this test can be omitted as the test given in annex I will suffice.

#### **C.2 Procedure**

**C.2.1** Connect a water gauge to a point near the burner that has the highest rate of gas consumption. Check and note the gas pressure when all the appliances of the installation are operating at their maximum level.

**C.2.2** Repeat C.2.1 but with the water gauge connected to a point near the burner farthest from the regulator.

**C.2.3** The piping can be regarded as adequate in size if in neither C.2.1 nor C.2.2 the gas pressure is less than 2,5 kPa.

**Annex D**

(informative)

**Occupancy classification in accordance with SANS 10400**

**Table D.1 — Occupancy or building classifications in accordance with SANS 10400**

1	2
Class of occupancy	Occupancy
<b>A1</b>	<b>Entertainment and public assembly</b> Occupancy where persons gather to eat, drink, dance or participate in other recreation.
<b>A2</b>	<b>Theatrical and indoor sport</b> Occupancy where persons gather for the viewing of theatrical, operatic, orchestral, choral, cinematographical or sport performances.
<b>A3</b>	<b>Places of instruction</b> Occupancy where school children, students or other persons assemble for the purpose of tuition or learning.
<b>A4</b>	<b>Worship</b> Occupancy where persons assemble for the purpose of worshipping.
<b>A5</b>	<b>Outdoor sport</b> Occupancy where persons view outdoor sports events.
<b>B1</b>	<b>High risk commercial service</b> Occupancy where a non-industrial process is carried out and where either the material handled or the process carried out is liable, in the event of fire, to cause combustion with extreme rapidity or give rise to poisonous fumes, or cause explosions.
<b>B2</b>	<b>Moderate risk commercial service</b> Occupancy where a non-industrial process is carried out and where either the material handled or the process carried out is liable, in the event of fire, to cause combustion with moderate rapidity but is not likely to give rise to poisonous fumes, or cause explosions.
<b>B3</b>	<b>Low risk commercial service</b> Occupancy where a non-industrial process is carried out and where neither the material handled nor the process carried out falls into the high or moderate risk category.
<b>C1</b>	<b>Exhibition hall</b> Occupancy where goods are displayed primarily for viewing by the public.
<b>C2</b>	<b>Museum</b> Occupancy comprising a museum, art gallery or library.
<b>D1</b>	<b>High risk industrial</b> Occupancy where an industrial process is carried out and where either the material handled or the process carried out is liable, in the event of fire, to cause combustion with extreme rapidity or give rise to poisonous fumes, or cause explosions.
<b>D2</b>	<b>Moderate risk industrial</b> Occupancy where an industrial process is carried out and where either the material handled or the process carried out is liable, in the event of fire, to cause combustion with moderate rapidity but is not likely to give rise to poisonous fumes, or cause explosions.
<b>D3</b>	<b>Low risk industrial</b> Occupancy where an industrial process is carried out and where neither the material handled nor the process carried out falls into the high or moderate risk category.
<b>D4</b>	<b>Plant room</b> Occupancy comprising usually unattended mechanical or electrical services necessary for the running of a building.

Table D.1 (concluded)

1	2
Class of occupancy	Occupancy
<p><b>E1</b></p> <p><b>E2</b></p> <p><b>E3</b></p>	<p><b>Place of detention</b> Occupancy where people are detained for punitive or corrective reasons or because of their mental condition.</p> <p><b>Hospital</b> Occupancy where people are cared for or treated because of physical or mental disabilities and where they are generally bedridden.</p> <p><b>Other institutional (residential)</b> Occupancy where groups of people who either are not fully fit, or who are restricted in their movements or their ability to make decisions, reside and are cared for.</p>
<p><b>F1</b></p> <p><b>F2</b></p> <p><b>F3</b></p>	<p><b>Large shop</b> Occupancy where merchandise is displayed and offered for sale to the public and the floor area exceeds 250 m<sup>2</sup>.</p> <p><b>Small shop</b> Occupancy where merchandise is displayed and offered for sale to the public and the floor area does not exceed 250 m<sup>2</sup>.</p> <p><b>Wholesalers' store</b> Occupancy where goods are displayed and stored and where only a limited selected group of persons is present at any one time.</p>
<p><b>G1</b></p>	<p><b>Offices</b> Occupancy comprising offices, banks, consulting rooms and other similar usage.</p>
<p><b>H1</b></p> <p><b>H2</b></p> <p><b>H3</b></p> <p><b>H4</b></p>	<p><b>Hotel</b> Occupancy where persons rent furnished rooms, not being dwelling units.</p> <p><b>Dormitory</b> Occupancy where groups of people are accommodated in one room.</p> <p><b>Domestic residence</b> Occupancy consisting of two or more dwelling units on a single site.</p> <p><b>Dwelling house</b> Occupancy consisting of a dwelling unit on its own site, including a garage and other domestic outbuildings, if any.</p>
<p><b>J1</b></p> <p><b>J2</b></p> <p><b>J3</b></p> <p><b>J4</b></p>	<p><b>High risk storage</b> Occupancy where material is stored and where the stored material is liable, in the event of fire, to cause combustion with extreme rapidity or give rise to poisonous fumes, or cause explosions.</p> <p><b>Moderate risk storage</b> Occupancy where material is stored and where the stored material is liable, in the event of fire, to cause combustion with moderate rapidity but is not likely to give rise to poisonous fumes, or cause explosions.</p> <p><b>Low risk storage</b> Occupancy where the material stored does not fall into the high or moderate risk category.</p> <p><b>Parking garage</b> Occupancy used for storing or parking of more than 10 motor vehicles.</p>

**Annex E**  
(normative)

**Ventilation requirements**

**E.1 General**

Ventilation is normally required if the oxygen in the air in a room will be used up by flames burning, people breathing, etc. If sufficient ventilation is not provided, the existing oxygen in the air will be used up, the flames will start to smoke and eventually go out and the people will lapse into unconsciousness and eventually suffocate.

These processes start to happen when the normal oxygen content of the air in a room (21 % of fresh air is oxygen and 79 % is nitrogen) is reduced by about a third, i.e. to  $\pm 14$  %.

**E.2 Installation of vents**

Vents shall be installed in such a way that they cannot be blocked.

**E.3 Size of vents**

**E.3.1** The size of a vent is related to the following three important factors:

- a) the total maximum heat input of the appliances installed in the room;
- b) the size (volume) of the room; and
- c) whether the installed vents vent to the outside or to another room.

The following example may be used to determine the size of a vent:

There are 12 holes in a vent. If the size of each hole is  $1\text{ cm} \times 1\text{ cm}$  (length = 1 cm and width = 1 cm), then the total effective area of free air is  $12 \times (1 \times 1)\text{ cm}^2$ .

**E.3.2** When venting from a room to the outside, two vents with a total free cross-sectional area of not less than  $13\text{ cm}^2/\text{MJ}$  of heat input shall be installed, one at high level and one at low level.

**E.3.3** When venting from one room to another room, two vents of size  $300\text{ cm}^2$  per 50 MJ/h heat input shall be installed, one at high level and one at low level, provided one of the rooms is permanently ventilated to the outside. This requirement shall not apply to vent-free heaters in bedrooms (see E.5.1).

**E.4 Venting requirements for gas cylinders (up to 19 kg) placed inside a building or cupboard**

When placing a gas cylinder inside a building, the following requirements shall be complied with:

- a) the ventilation provided shall be to the outside atmosphere;
- b) the gas cylinder, if it is not placed in a cupboard, shall be placed as close as possible to the door leading to the outside of the building;
- c) where the requirement of (b) cannot be attained, there shall be cross ventilation. This can be achieved by having a minimum of two airbricks in close proximity to each other on the external wall and as low as possible to the floor level. They need not be staggered and they can all be at the same level;

- d) where a gas container needs to be placed inside a cupboard, the cupboard door shall have ventilation available, for example a lattice door or ventilation slots (see figure 16). The back of the cupboard shall preferably be ventilated to the outside atmosphere;
- e) no electrical connections or plug points shall be allowed in the same section as the gas cylinder; and
- f) the cupboard shall be sealed to ensure that no gas can leak from one section of the cupboard to another section.

## **E.5 Vent-free heater installation requirements with specific reference to the provision of permanent free air ventilation**

**E.5.1** A vent-free heater shall not be installed in a bedroom without the provision of permanent ventilation (see 3.21.1). Where the heat input is greater than  $0,37 \text{ MJ/m}^3$  of room volume, permanent ventilation shall be provided in the room.

**E.5.2** The minimum size room volume in  $\text{m}^3$  in which the appliance may be installed without the provision of permanent ventilation shall be based on the following requirement:

A 25 MJ appliance requires a minimum room volume of

$$25 \div 0,37 = 67,57 \text{ m}^3$$

**E.5.3** When applying the calculation in E.5.2, the heat input of any other gas or solid fuel or paraffin-burning appliances shall be added to the heat input of the vent-free heater to be installed.

**EXAMPLE 1** If existing appliances of the type indicated above, having a heat input of 15 MJ, share the same room volume as a vent-free heater with a heat input of 40 MJ, then the calculation to establish the minimum room volume allowed for the installation of the vent-free heater without the provision of permanent free air ventilation would be

$$(15 + 40) \div 0,37 = 148,65 \text{ m}^3$$

**EXAMPLE 2** If the total available room volume is  $90 \text{ m}^3$  and there are already appliances in the room with a heat input of 12 MJ, then the calculation to find the maximum heat input that may be added to that room volume without the provision of permanent free air ventilation would be:

$$12 \div 0,37 = 32,43 \text{ m}^3$$

$$90 - 32,43 = 57,57 \text{ m}^3$$

$$57,57 \times 0,37 = 21,30 \text{ MJ}$$

**E.5.4** Where an adjoining room or rooms share(s) a common opening with the room in which the appliance is to be installed, then the room volumes of both rooms may be added together for the purposes of compliance with the calculation in E.5.2, providing that the opening between the two rooms is permanently open and cannot be closed, e.g. by a door.

**EXAMPLE 1**

$$\text{Room A} = 6 \text{ m} \times 5 \text{ m} \times 2,7 \text{ m} = 81 \text{ m}^3$$

$$\text{Room B} = 5 \text{ m} \times 4,5 \text{ m} \times 2,7 \text{ m} = 60,75 \text{ m}^3$$

Thus the total available room volume is  $81 + 60,75 = 141,75 \text{ m}^3$ . The maximum heat input that may be installed without the provision of permanent free air ventilation is  $141,75 \times 0,37 = 52,45 \text{ MJ}$ .

## **Annex F**

(informative)

### **Testing the adjustment of burners**

**F.1** Check the operation of each burner of each appliance and ensure that the aeration controls are correctly adjusted and locked.

**F.2** Check the performance of the thermostats on ovens, etc. with a suitable thermometer.

**F.3** Ensure that the pilot lights and flame failure devices function correctly.

**F.4** Check all water heaters for water discharge temperature and ensure that their adjustments are correctly set.

## **Annex G**

(informative)

### **Testing the system performance of low-pressure regulators**

**G.1** Connect a water manometer to some convenient point in the low-pressure system as close as possible to the regulator outlet.

**G.2** Turn on the gas supply and purge the air from the system.

**G.3** Check and note the gas pressure with

- a) all the burners alight,
- b) only the smallest burner in the installation alight, and
- c) all the burners turned off.

**G.4** The type and size of the regulator and the performance of the system can be regarded as satisfactory if there is no fluctuation of pressure in G.3(a) and G.3(b), and if the pressure

- a) does not fall below 2,7 kPa in G.3(a),
- b) does not exceed 3,4 kPa in G.3(b), and
- c) does not exceed 4,0 kPa in G.3(c).

## Annex H

(informative)

### Determination of pipe sizes in the low-pressure stage

**H.1** To determine the size(s) of pipe required in a gas pipe system, it is necessary to estimate the amount of gas (expressed in terms of kJ/h) that passes through each section of pipe when all the appliances are turned full-on. The rating of each appliance is always given in the manufacturer's service manual but if this is not available, the ratings given in table H.1 could serve as a guide. The size of pipe needed for each section of the system is determined (as shown in the following example, which is based on table H.1) from the rating of each appliance in the system, the length of each section, and the data given in tables H.2 and H.3.

**EXAMPLE** An installation comprises a single-point (sink) instantaneous water heater, a normal domestic stove, a refrigerator and two lights. Copper tubing is used. The appliances are positioned as shown in figure H.1.

From table H.1, the relevant appliance ratings are as follows:

Water heater	37 000 kJ/h
Stove	42 000 kJ/h
Refrigerator	2 000 kJ/h
Two lights	4 000 kJ/h
Total rating	85 000 kJ/h

Therefore (see figure H.1),

Section A of the pipe carries	85 000 kJ/h
Section B of the pipe carries	39 000 kJ/h
Section C of the pipe carries	2 000 kJ/h
Section D of the pipe carries	46 000 kJ/h
Section E of the pipe carries	4 000 kJ/h
Section F of the pipe carries	2 000 kJ/h

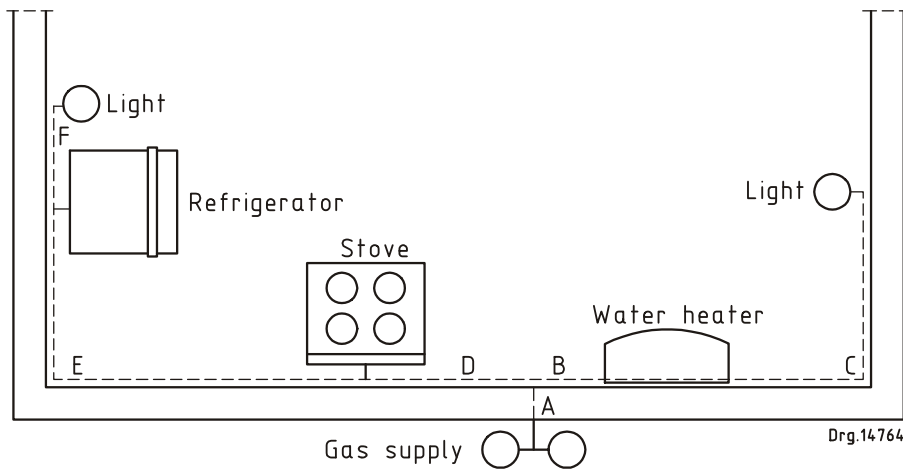
The required pipe sizes are then determined from table H.2 using the lengths of the various pipe runs. For example, if the length of section D is 3,2 m, pipe of nominal outside diameter (OD) of 15 mm is needed, and for section E (length 7 m) the size can be reduced to 8 mm.

**H.2** For each fitting in the system, substitute the appropriate of the following equivalent lengths of pipe:

Elbow or tee	600 mm
Connector or 90° bend	800 mm

**Table H.1 — Appliance ratings**

1	2
Appliances	Rating kJ/h
Gas stove, normal domestic	42 000
Gas stove, large domestic	63 000
Portable hotplate (2-burner)	16 000
Instantaneous water heater – multipoint or bath heater	74 000
Instantaneous water heater – single-point or sink heater	37 000
Gaslight	2 000
Refrigerator	2 000
Gas iron	3 000
Space heater – large size with flue	20 000
Space heater – small portable type	5 000



**Figure H.1 — Example layout**



Table H.2 — Sizes for copper tubing

1	2	3	4	5	6	7	8	9
Length of pipe m	Pipe size (OD) mm							
	Gas flow kJ/h <sup>a</sup>							
	5 000	10 000	20 000	40 000	60 000	80 000	100 000	120 000
< 3	8	8	10	10	15	15	15	15
3 – 6	8	8	10	15	15	15	18	18
7 – 9	8	10	10	15	15	18	18	18
10 – 12	8	10	10	15	15	18	18	20
13 – 15	8	10	10	15	18	18	18	20
16 – 25	10	10	15	15	18	18	20	20
26 – 30	10	10	15	15	18	20	20	20
<sup>a</sup> At 3 kPa pressure.								

**H.3** If steel pipes are used, the required pipe sizes are determined from table H.3.

Table H.3 — Sizes for steel piping

1	2	3	4	5	6	7
Length of pipe m	Pipe size inside diameter (ID) mm					
	Gas flow kJ/h <sup>a</sup>					
	20 000	40 000	60 000	80 000	100 000	120 000
< 3	10	10	10	10	15	15
3 – 6	10	10	10	15	15	15
7 – 9	10	10	10	15	15	18
10 – 12	10	10	10	15	15	15
13 – 15	10	10	15	15	15	15
16 – 25	10	10	15	15	15	15
26 – 30	10	15	15	15	20	20
<sup>a</sup> At 3 kPa pressure.						

**H.4** Typical sizes of connecting pipes for use with certain appliances are given in table H.4.

**Table H.4 — Typical sizes of connecting pipes**

Dimensions in millimetres

1	2	3
<b>Appliance</b>	<b>Steel pipes</b>	<b>Copper tubes</b>
	<b>ID</b>	<b>OD</b>
Gas stove, normal domestic	8	10
Gas stove, large domestic	10	15
Gaslight	8	8
Space heater (portable)	8	8
Refrigerator	8	8
Water heater, instantaneous		
Single point	10	10
Multipoint	10	15
Bath	10	10
Sink-storage	8	10

**H.5** When a pipework system is designed, provision should be made for additional appliances which might be installed at a later date and pipe sizes should, therefore, be large enough to cater for such future extensions.

## Annex I (normative)

### Gas container manifolds and supply systems

#### I.1 General

**I.1.1** This annex covers the design, construction, installation, commissioning, inspection and maintenance of gas container manifolds and supply systems.

**I.1.2** An LPG cylinder manifold provides a convenient means of connecting 48 kg (113 L) cylinders or, for larger installations, 196 kg (454 L) cylinders, in parallel to a common outlet thus deriving the benefit of providing a source of supply many times greater than what is possible from a single cylinder.

**I.1.3** In normal practice, the manifold shall be so constructed that the operating group of cylinders is duplicated on the other half of the manifold and shall be controlled by means of either a special changeover valve (manual or automatic), or an automatic changeover regulator together with isolating valves. This ensures easy switching from the operating group of cylinders to the standby group without interrupting the supply.

**I.1.4** The use of LPG manifolded cylinders is covered by this part of SANS 10087 for both conventional cylinder installations and for roof installations.

**I.1.5** Vapour manifolds (see figure I.1) are sized for maximum continuous consumption related to the draw-off rates of LPG vapour from LPG containers given in table I.1.

**Table I.1 — Draw-off rates of LPG vapour**

1	2	3
Nominal container size		Approximate evaporation capacity
L	kg	kg/h
113	48	0,92
454	196	2,3

**I.1.6** If the consumer's consumption demands exceed the evaporation capabilities of the containers allowed on a site under the applicable national standards, other means of supply (for example liquid manifolds (see figure I.2) shall be examined.

**I.1.7** In liquid manifolds, the liquid shall be withdrawn from cylinders equipped with eductor tubes and use shall be made of a vaporizer after the manifold to supply vapour to the consumer's appliances.

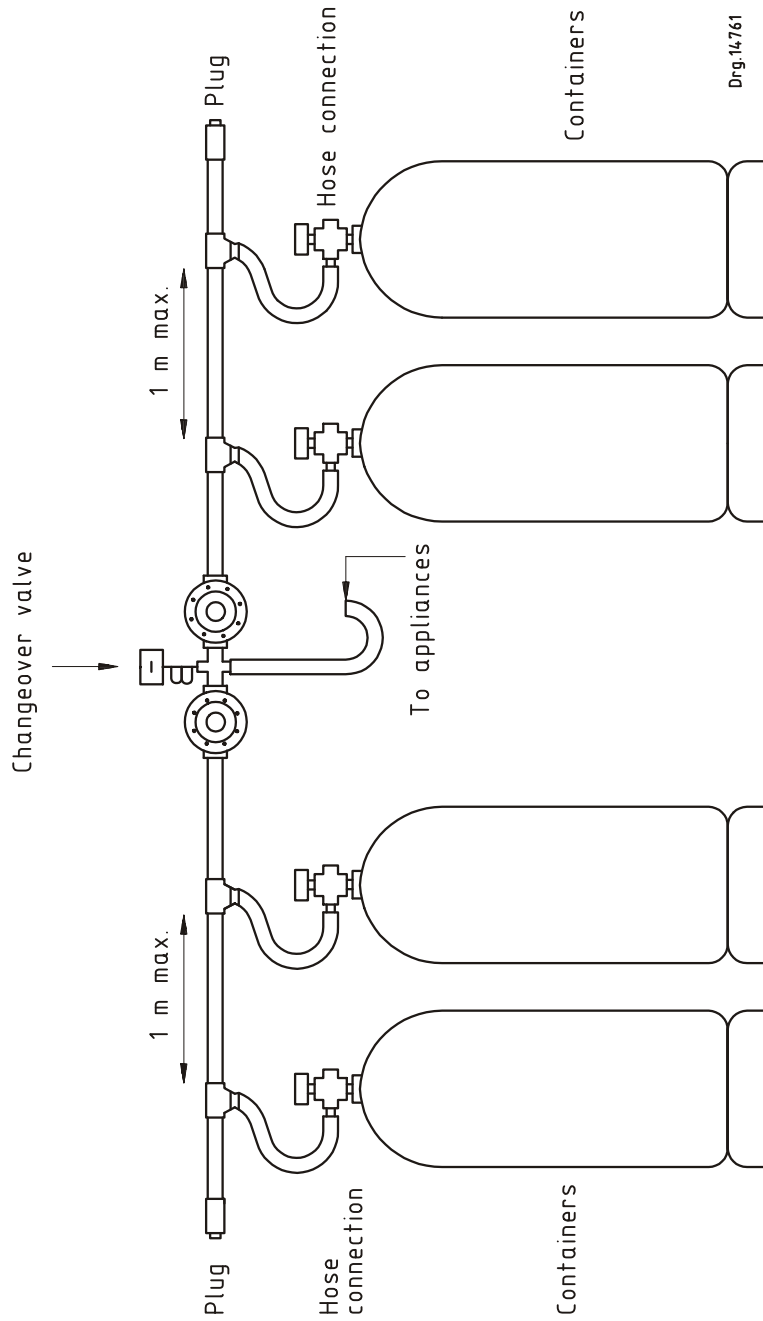


Figure I.1 — Typical vapour withdrawal installation

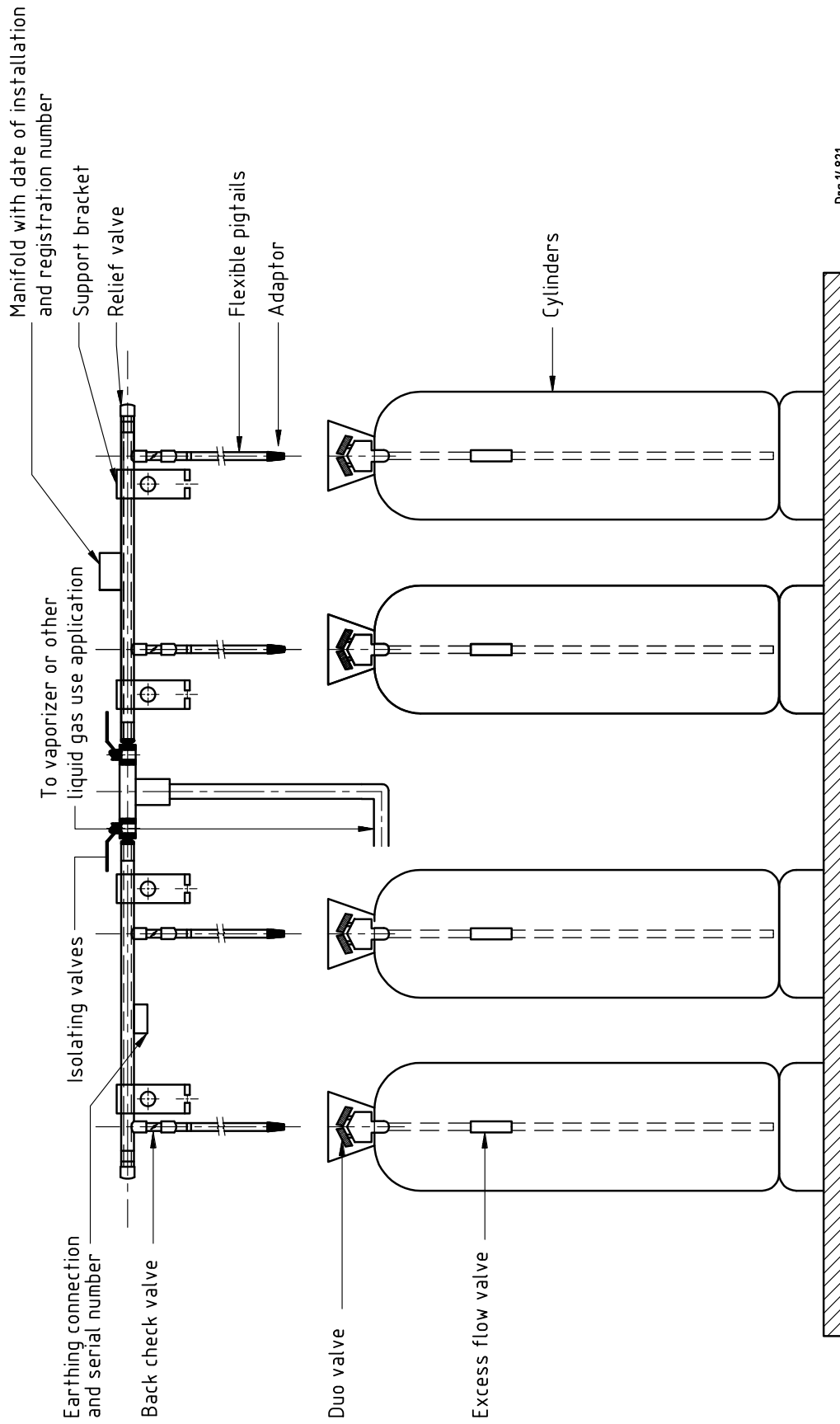


Figure I.2 — Typical liquid withdrawal installation

## **I.2 Design and construction**

**I.2.1** LPG manifolds shall be manufactured from

- a) seamless steel piping that complies with the requirements of BS 1600 or API Spec 5L, or equivalent, or
- b) SA 312 seamless stainless steel piping that complies with the requirements of ASME-BPVC 7,
- c) heavy gauge steel fittings that comply with SANS 62-1, or
- d) class 1 copper (for vapour use only) with soldered joints and fittings that comply with the requirements of SANS 1067-2.

**I.2.2** If screwed pipes are used in the construction of the manifold, at least schedule 80 piping shall be used.

**I.2.3** If the steel manifold is of welded or flanged construction, at least schedule 40 piping shall be used.

**I.2.4** If the manifold is of copper tube construction, it shall be constructed from a class 2 tube with a minimum diameter of 15 mm and a wall thickness of 0,9 mm and have a working pressure of 5 100 kPa. Copper manifolds shall only be used for vapour withdrawal. These manifolds shall be supplied as an assembled unit together with the test certificate indicating the test pressure (3 000 kPa) to which the manifold has been tested. The markings as required in I.2.5 shall be fixed to the manifold.

**I.2.5** The manifold should be permanently marked with

- a) a unique serial number,
- b) the test pressure in kilopascals, and
- c) the manufacturer's identification symbol.

**I.2.6** The manifold shall withstand a pressure test of 3 000 kPa  $^{+50}_0$  kPa.

**I.2.7** The manifold shall be cleaned internally and externally and shall be free from contaminants such as grease, oily deposits and welding slag.

**I.2.8** Manifolds and their supporting structure shall be protected against corrosion, especially in the highly corrosive environment of coastal areas. Manifolds should be painted or coated for identification and protection with the finish colour ("stone" in compliance with SANS 10140-3). Labelling to differentiate vapour and liquid manifolds shall be in accordance with SANS 10140-3.

**I.2.9** However, if a manifold is installed in an oil company's storage depot or other property owned by such company in South Africa, it can be colour coded in compliance with the industry agreement, i.e. manifolds for LPG liquid are painted continuously blue (colour F29 of SANS 1091 or an equivalent colour) and those for LPG vapour are painted continuously yellow (colour C61 of SANS 1091 or an equivalent colour).

**I.2.10** Manifolds for liquid use shall have a hydrostatic relief valve situated between any two points of the system that might cause the containment of liquid. The relief valve shall be set to start to discharge at a pressure of 2 750 kPa  $+10_0$  %.

Vapour manifolds, which will be used with cylinders that do not incorporate their own relief valve, should have a relief valve of sufficient capacity to protect the system in the event of fire.

**I.2.11** Manifolds for liquid use should use check valves (non-return valves) to protect the system in the event of any flexible pigtail rupture.

NOTE In the event of a flexible pigtail rupture, the excess flow valve incorporated in the liquid withdrawal valve will reduce the escape of liquid through the cylinder attached by the pigtail. However, the reverse flow through the system from other manifolded cylinders might not be sufficient to operate all excess flow valves in the remaining cylinders.

**I.2.12** The attachment of the manifold to the cylinders shall be made by means of flexible pigtails, using LPG hose that complies with SANS 252 or equivalent. Pigtails shall be so constructed that their electrical resistance does not exceed 0,75  $\Omega$ /m. The fitting connecting the cylinder to the manifold shall comply with the valve connection requirements of SANS 199 for liquids or vapour, whichever is applicable. The length of pigtails shall be not more than 1 m and, in the case of pigtails for liquids, shall be of internal diameter at least 8 mm in order to ensure acceptable cylinder excess flow valve closure. The date of manufacture of the pigtail shall be evident in a manner to facilitate replacement every five years. The pigtail shall withstand a test pressure of 3 000 kPa. Where cylinders are not exchangeable, fixed pipework may be used.

### **I.3 Installation**

**I.3.1** The system shall be installed in accordance with the relevant safety distances of this part of SANS 10087 and by a registered installer.

**I.3.2** Where the gas installation capacity exceeds 100 kg, the installation shall be approved by the local authority and plans shall be submitted to the local authority.

**I.3.3** The manifold shall be mounted against a solid wall or a non-combustible structure at an appropriate height using an approved method of bracketing.

**I.3.4** Copper manifolds shall be fixed to the solid wall or a non-combustible structure above the height of the cylinders. This is to prevent possible damage to the manifold when cylinders are replaced.

**I.3.5** The brackets and clamps anchoring the copper manifold shall be equivalent to the number of cylinders on the manifold, but shall not be less than four brackets.

**I.3.6** Pipe clamps shall clasp the copper tube in its entirety. An insulation band shall be placed between the tube and the enclosing clamp. The anchor of the pipe clamp shall be at least 40 mm into the wall or concrete.

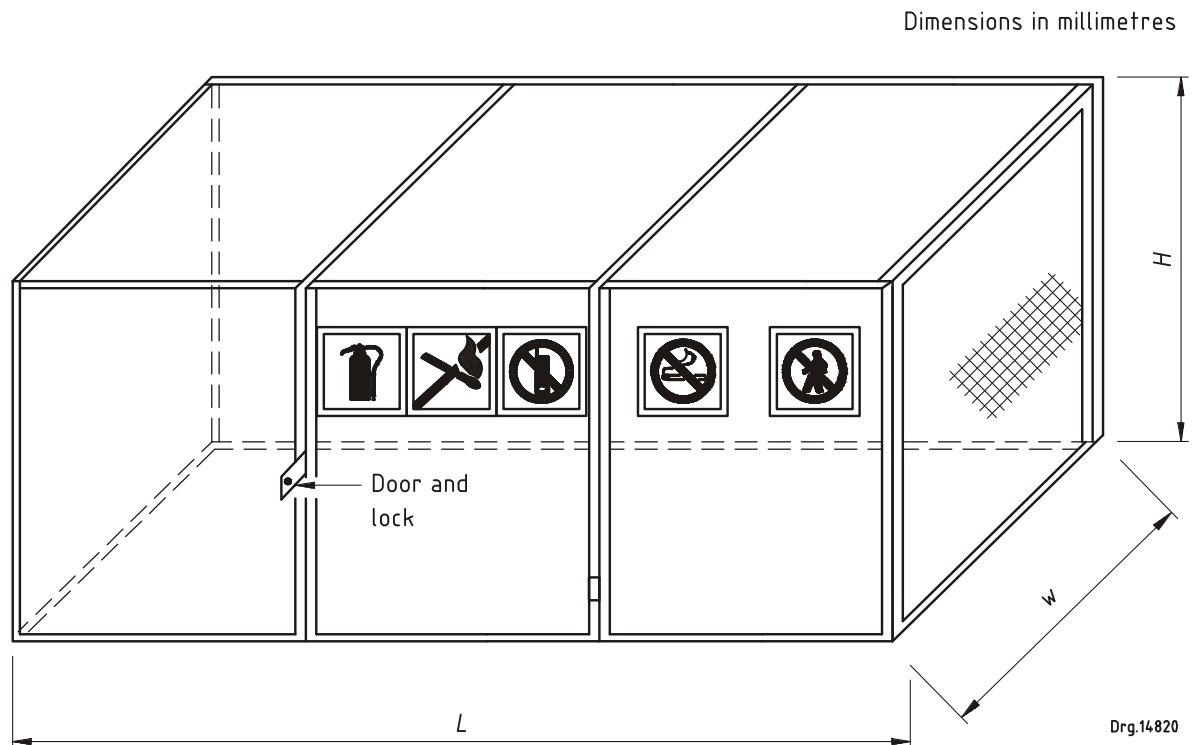
**I.3.7** If filling operations are intended to be performed on site, the manifold installation shall be effectively connected to earth.

**I.3.8** Connecting containers should be located on a firm base, preferably on a concrete or screed plinth raised above the level of the surrounding ground and so constructed as to allow for the drainage of rain water. Where so required by the approving authority, the installation shall be fenced

## SANS 10087-1:2008

Edition 5

or walled to create an enclosure to prevent unauthorized access (see figure I.3) and it shall be secure and comply with the requirements of this part of SANS 10087. Sufficient room shall be allowed within the enclosure to permit the unimpeded exchange of cylinders. Any installation shall be fitted with signage indicating no smoking, no naked flame, no unauthorized entry and no cellular phones allowed, i.e. the appropriate pictograms PV 1, PV 2, PV 3 and PV 27 in SANS 1186-1. The site and its surrounds shall be clear of combustibles, weeds and unauthorized storage.



$H$  = height at least 300 mm above the container

$L$  = length of the manifold plus 150 mm on either side

$W$  = sufficient width to allow free cylinder changing

**Figure I.3 — Typical manifold cage installation**

**I.3.9** A nameplate shall be fitted to the manifold assembly and shall contain the following information:

- a) name of manifold owner;
- b) whether it is LPG vapour/LPG liquid (whichever is applicable);
- c) emergency telephone number of the supplier;
- d) name and registration number of installer;
- e) manifold serial number; and
- f) installation date.



## **I.4 Construction and assembly of copper manifolds**

### **I.4.1 General**

**I.4.1.1** Manifolds manufactured from copper tube and fittings shall not be manufactured on site.

**I.4.1.2** The surfaces of both the copper tube and the fitting to be joined shall both be cleaned with either fine grit emery cloth or steel wool.

**I.4.1.3** The solder used in the manufacture of capillary joints shall comply with the requirements of SANS 24 and shall be type 97/3. Solders that contain lead, acid core or resin shall not be used.

**I.4.1.4** The amount of solder used shall be equal to the diameter of the tube that is used (e.g. 15 mm tube = 15 mm length of solder). The diameter of the solder is normally 2 mm.

**I.4.1.5** The flux used in this application shall have an ASTM B 813 certification. The flux shall be able to remove residual traces of oxide, and prevent the reformation of oxide. The flux also assists with the capillary action and shall readily flow out of the joint as the solder flows in.

**I.4.1.6** Oxy-acetylene shall not be used as a heat source as the heat is too severe and causes overheating, thereby burning the flux, annealing the copper tube and possibly melting the tube.

### **I.4.2 Procedure**

**I.4.2.1** Cut the copper tube to the required length. Ensure that the copper tube ends are cut square and all the burr has been removed.

**I.4.2.2** Apply the flux sparingly to both the copper tube and the fitting that is joined. Ensure that the copper tube end is seated firmly against the base of the fitting.

**I.4.2.3** Apply the flame to the assembled joint, concentrating the heat at the centre of the fitting. Apply the solder.

NOTE The heat of the pipe and fitting should be sufficient to melt the solder when applied with the use of a direct flame.

**I.4.2.4** After a short cooling period, wipe the assembly with a damp cloth to remove the excess flux.

## **I.5 Commissioning**

**I.5.1** Before the installation is operated, the system shall be checked by the installer for rigidity and to ensure that cylinders are correctly assembled to the manifold by their flexible pigtailed.

**I.5.2** Individual cylinder valves should then be opened slowly and fully and the system should be checked for leaks using an approved leak detection solution or system on both banks of the manifold.

**I.5.3** The regulator delivery pressure setting and performance should be checked for accurate operation.

**I.5.4** Any vaporizer in the system should be examined before start up for compliance with the manufacturer's requirements.

## **I.6 Inspection and maintenance**

**NOTE** The manifold system should be maintained on a planned inspection basis at intervals not exceeding five years. If conditions demand, this period should be reduced.

**I.6.1** Faulty parts or equipment may only be replaced on site.

**I.6.2** Flexible pigtails shall be inspected for signs of rupture, cracking, chafing and perishing and shall be replaced if necessary. If over five years old (see the date mark on the hose/brass fitting, see also I.2.12), they shall be replaced automatically.

**I.6.3** The brackets that secure the manifold shall be checked.

**I.6.4** The pipework shall be checked for corrosion.

**I.6.5** All valves shall be checked for free and full range of movement, positive shut off, corrosion and mechanical damage.

**I.6.6** The hydrostatic relief valve shall be inspected for corrosion and for any ingress of foreign bodies into the operating mechanism. The relief valve shall be replaced if it is more than five years old.

**I.6.7** The regulator shall be checked for correct setting and performance as well as for corrosion and mechanical damage. It shall be replaced or refurbished if it is more than seven years old.

**I.6.8** If fitted, gauges shall be checked for correct operation, and gauge faces shall be cleaned.

**I.6.9** The system shall be leak-tested at all joints using an approved leak detection solution or system. All joints where leaks become evident, shall be tightened or remade after the system has been depressurized.

**I.6.10** The enclosure shall be inspected for the condition of the plinth, and for the condition of any fencing or walling, including the gate. The prescribed signage shall still be in place and legible.

**I.6.11** The enclosure and immediate surroundings shall be cleared of any uncontrolled weed growth and accumulation of waste products.

**I.6.12** A check shall be made to ensure that all safety distances are maintained.

**I.6.13** Persons undertaking any routine cylinder change shall carry out visual inspections of the complete system. They shall perform a leak check on the cylinder system connections. Any defects found shall be reported to the owner.

## **I.7 Records**

The manifold shall be supplied together with the certificate of manufacture verifying that the design, construction and test procedures comply with all the requirements given in this part of SANS 10087. The serial number, date of manufacture and the manufacturer's name shall appear on the certification issued with the manifold.

**Annex J**  
(informative)

**Testing of the high-pressure stage of an installation**

**J.1 Testing of the system** (see figure J.1)

**J.1.1** Close off the low-pressure line.

**J.1.2** Break the pigtail joint of container A, and couple a pressure gauge between the pigtail and the valve of the container. (The gauge should have a range of 0 kPa to 600 kPa and a dial of diameter at least 100 mm.)

**J.1.3** Close the valve of container B and, by opening the valve of container A, charge the system with gas.

**J.1.4** Close the valve of container A and allow the system to stand for 5 min for equalization of temperature.

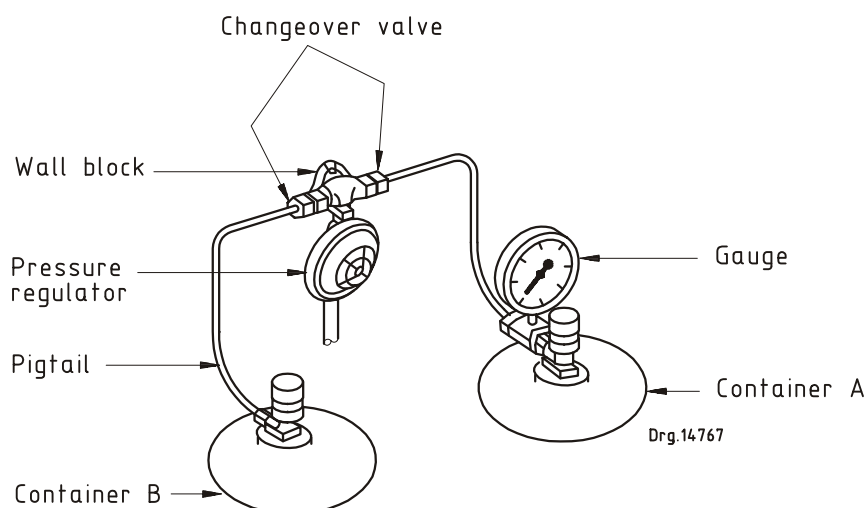
**J.1.5** Note the pressure on the pressure gauge.

**J.1.6** Allow the system to stand for a further 10 min. If the gauge pressure does not drop, the installation is sound.

**J.1.7** If the pressure drops, test individual joints, using soapy water to detect leaks. For installations that incorporate non-return valves, carry out the test with the gauge attached to each container (in turn).

**J.2 Testing of valves**

With the pigtails disconnected, test the container valves for leakage, using soapy water.



NOTE The use of copper pigtails should be discouraged because of work hardening.

**Figure J.1 — High-pressure leakage test**

## **Annex K**

(informative)

### **Testing of the low-pressure stage (as a whole) of an installation by U-gauge (see figure K.1)**

**K.1** The test requires a U-gauge and a fitting, one end of which has a tap and a tube nozzle for connecting the fitting to the U-gauge. The other end of the fitting is for coupling to the supply line under test.

**K.2** Make sure that all taps in the gas pipe system (including taps A and B) are closed.

**K.3** By opening the container valve, admit gas to the system.

**K.4** Open each tap on each appliance (in turn), purge the system of air, taking care to keep a flame near enough to the issuing gas-and-air stream to ignite it when the mixture becomes rich enough, and then close the tap.

**K.5** Ensure that the pressure regulator operates at the design pressure of the appliances.

**K.6** Open tap A.

**K.7** Close the container valve.

**K.8** Allow 10 min for temperature stabilization.

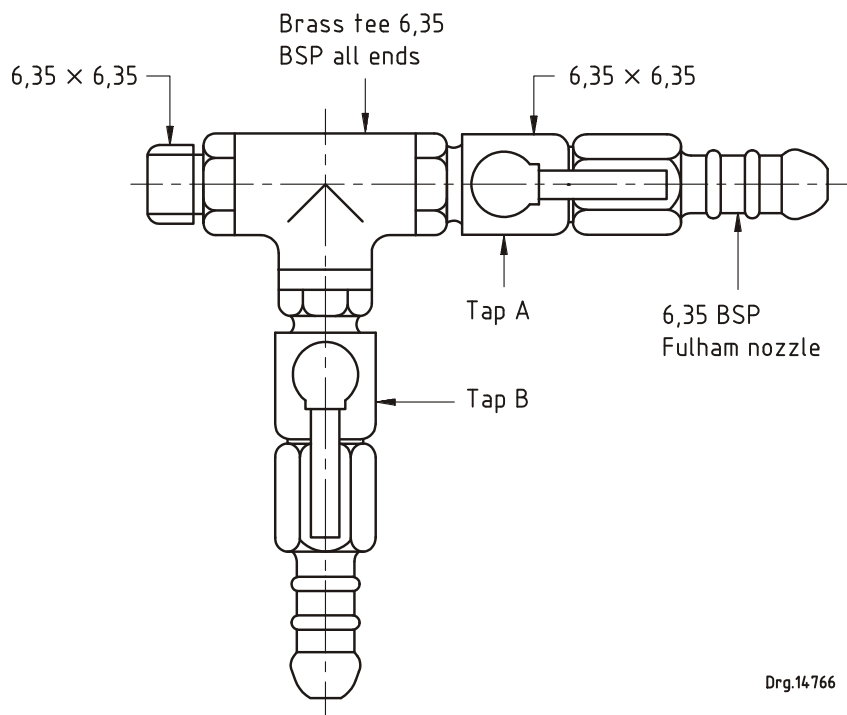
**K.9** Note the U-gauge reading.

**K.10** Close tap A.

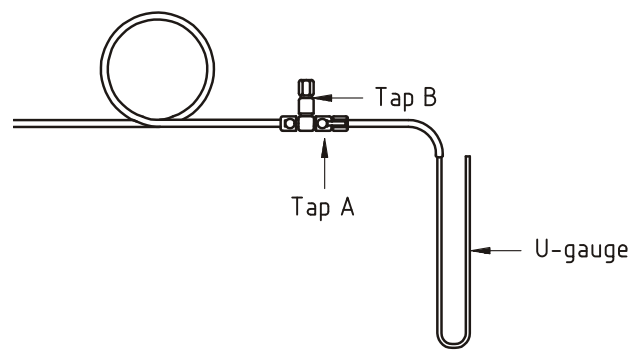
**K.11** After 10 min, again open tap A, and note the U-gauge reading. Any drop in pressure will indicate that there is a leak.

If this U-gauge reading is lower than that noted in K.9 by more than 25 mm water gauge, there is a leak in the system and the appliance(s), connections, taps, etc., should be carefully examined, and soapy water should be used to detect the leak.

Dimensions in millimetres



**a) Test fitting**



**b) Test arrangement**

**Figure K.1 — U-gauge test**

## **Bibliography**

ASME B 16.5, *Pipe flanges and flanged fittings NPS ½ through NPS 24.*

ASME B 16.9, *Factory-made wrought steel buttwelding fittings.*

ASME B 16.21, *Nonmetallic flat gaskets for pipe flanges.*

ASME B 31.3, *Process piping.*

SANS 1774, *Liquefied petroleum gases.*